

advanced FLOW engineering Cold Air Intake System

Instruction Manual P/N: 57-10019D / 57-10019R

Make: Nissan

Model: Patrol (Y61)

Year: 2017-2020

Engine: I6-4.8L



- Please read the entire instruction manual before proceeding.
- Ensure all components listed are present.
- If you are missing any of the components, call customer support at 951-493-7134.
- Ensure you have all necessary tools before proceeding.
- Do not attempt to work on your vehicle when the engine is hot.
- Retain factory parts for future use.

Label	Qty.	Description	Part Number
A1	1	Air Filter (Pro 5R)	24-91146
A2	1	Air Filter (Pro DRY S)	21-91146
B	1	Tube	05-5710019C1
C	1	Housing	05-5710019B2
D	1	Coupling, Silicone Bellow	05-01404
E	1	Fitting, Tube Coupling: 3/16"	03-50150
F	2	Clamp, 048 (2-9/16" - 3-1/2 ")	03-50007
G	1	Torx Bit: T20	03-50066
H	2	Screw, Torx: M4x8mm	03-50491
I	1	Seal, Trim: 3/4" Bulb (40"L)	05-01507
J	1	Hose, Vacuum: 5/32" ID (18"L)	05-00122

Installation will require the following tools:

Security T-20 Torx bit (included) & driver, 8mm & 10mm nut drivers, Slip-Joint Pliers, Phillips Head Screwdriver, 10mm socket and driver

Warranty Information available at <https://afepower.com/contact#warranty>

Emissions Disclaimer: This product is not currently CARB exempt and is not available for purchase in California or for use on any vehicle registered with the California Department of Motor Vehicles.

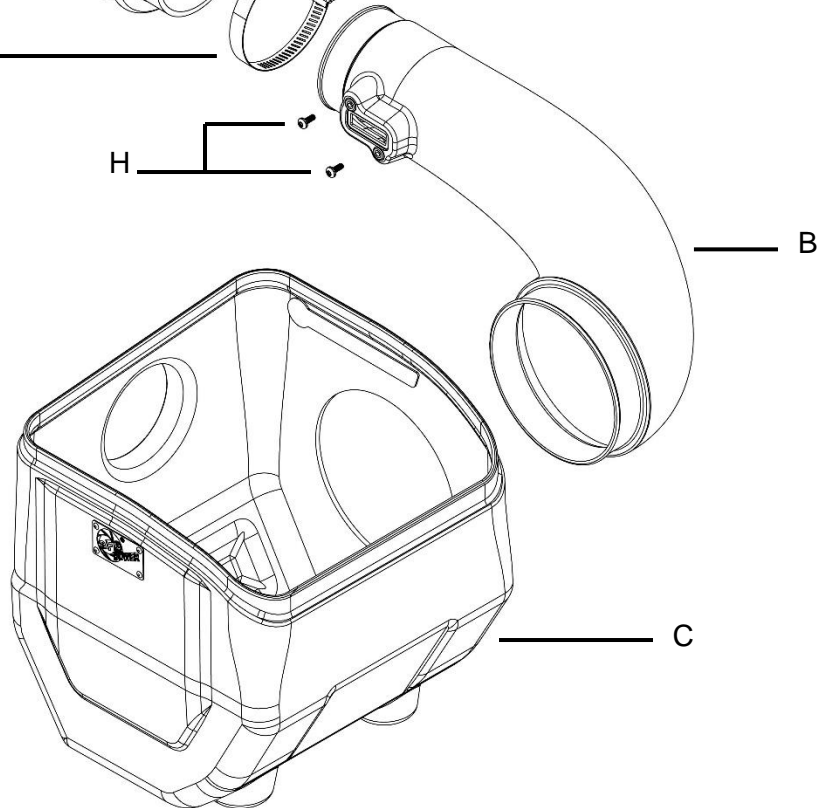
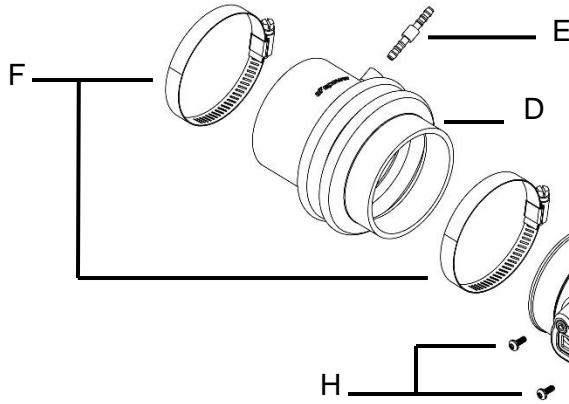
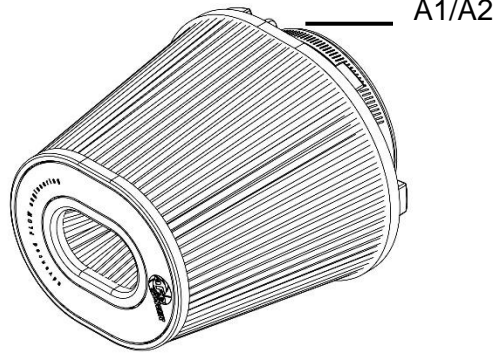
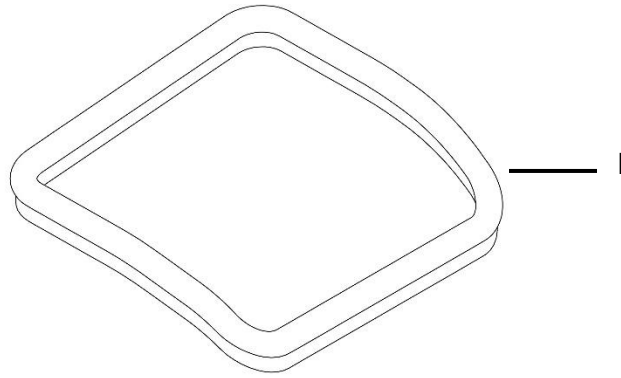

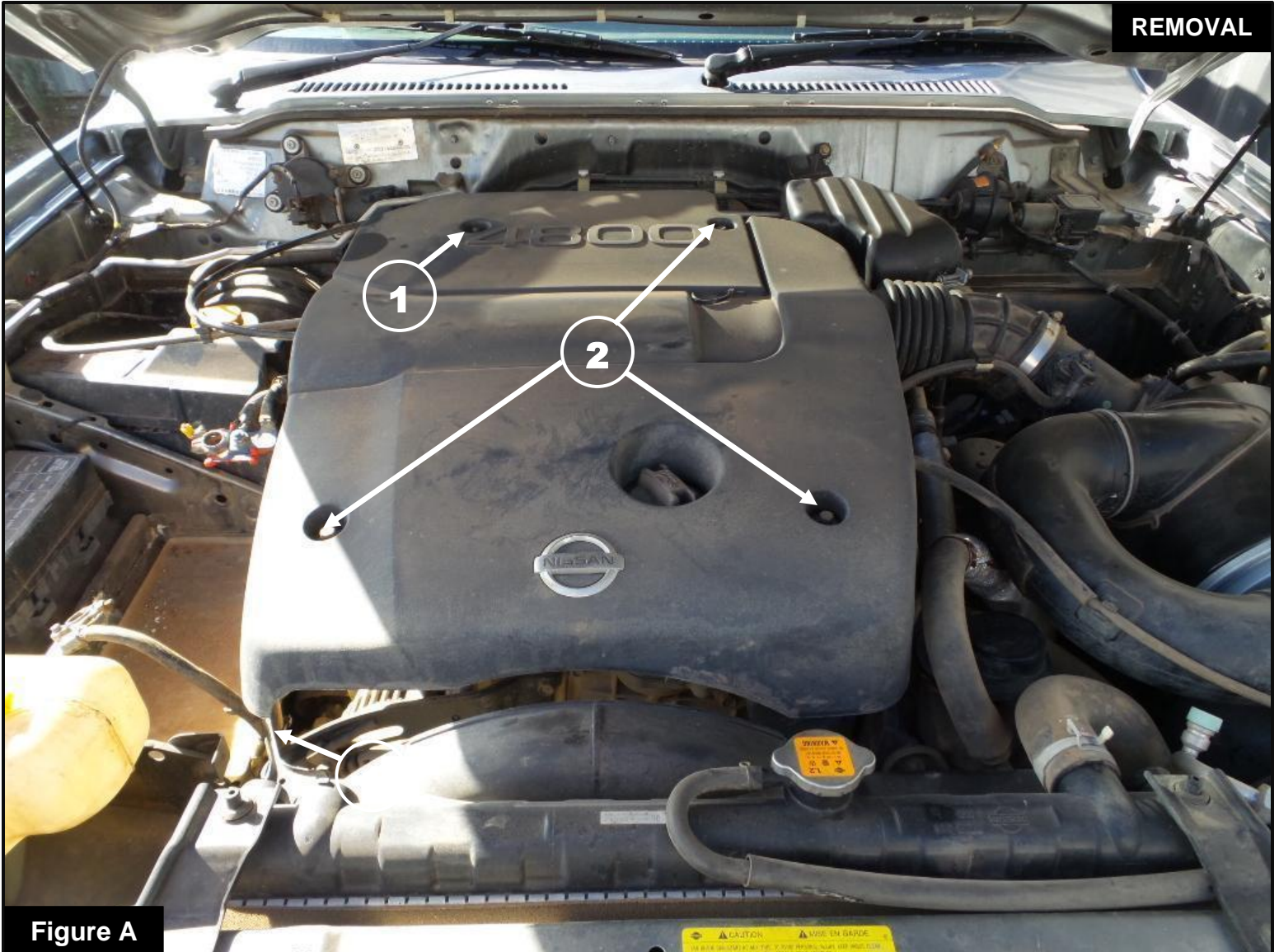
**Figure A****Refer to Figure A for Step 1**

Step 1: Use a 10mm nut driver to remove the rear nut (1) and three screws (2) holding the engine cover.

Remove the engine cover and set aside.

**Figure B****Refer to Figure B for Step 2**

Step 2: Remove the vacuum hose (3) from the retainer on the u-shape air duct. Push back the lock spring (4) and remove the u-shape air duct (5) from the air cleaner assembly.

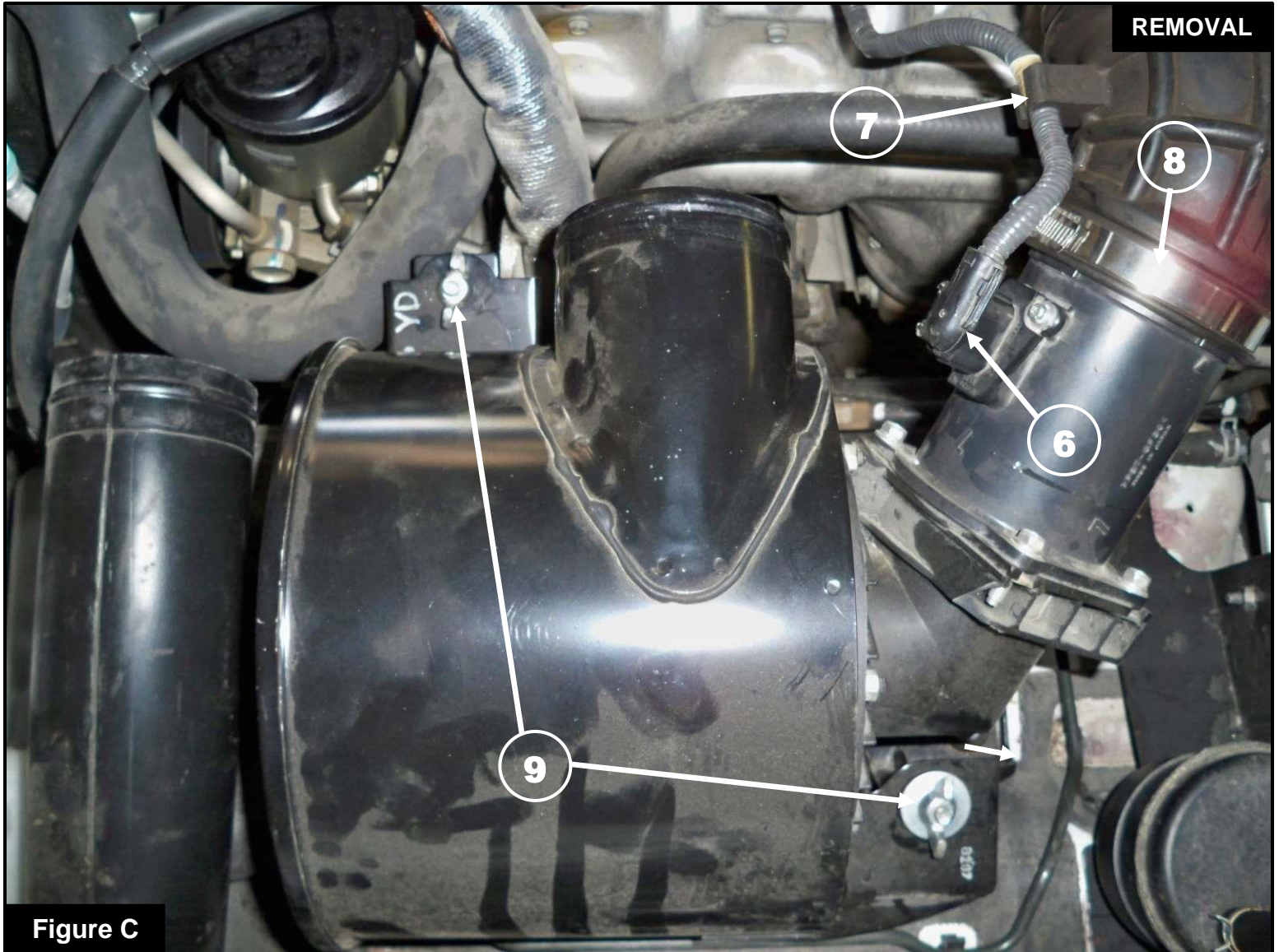

Figure C

Refer to Figure C for Steps 3-4

Step 3: Disconnect the mass air flow sensor (6) and disengage the wire loom (7) from the air intake tube.

Step 4: Use an 8mm nut driver to loosen the clamp (8) at the mass air flow sensor tube. Remove the two wing nuts and two washers (9) holding down the air cleaner assembly and remove the assembly.

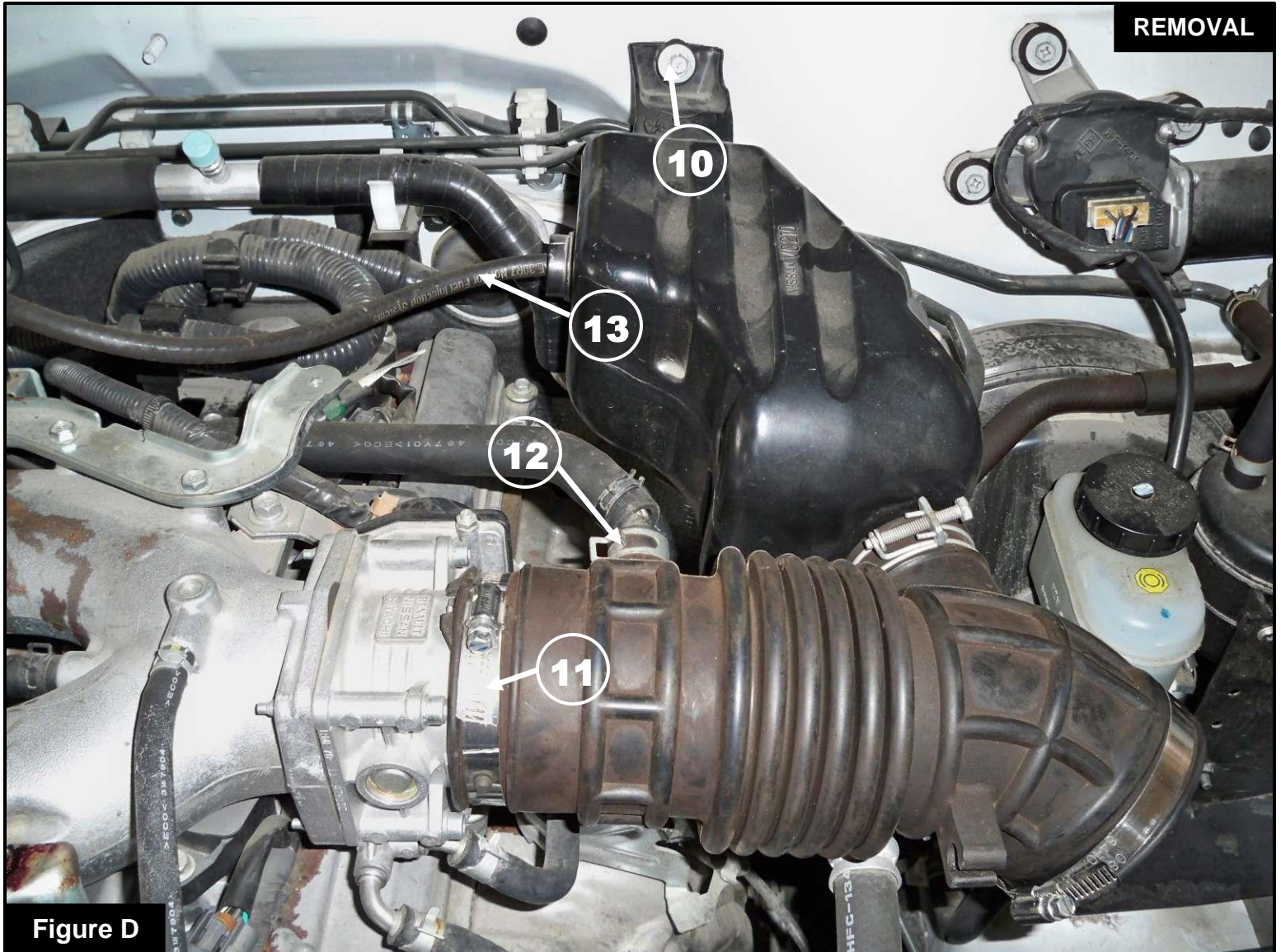

Figure D

Refer to Figure D for Step 5

Step 5: Use a 10mm nut driver to remove the screw ⑩ holding the air intake tube assembly resonator to the firewall. Use an 8mm nut driver to loosen the clamp ⑪ at the throttle body. Using pliers, remove the vent ⑫ tube to the air intake tube. Remove the small vacuum hose ⑬ from the air intake tube assembly resonator and the intake solenoid valve. Remove the complete air intake tube assembly.

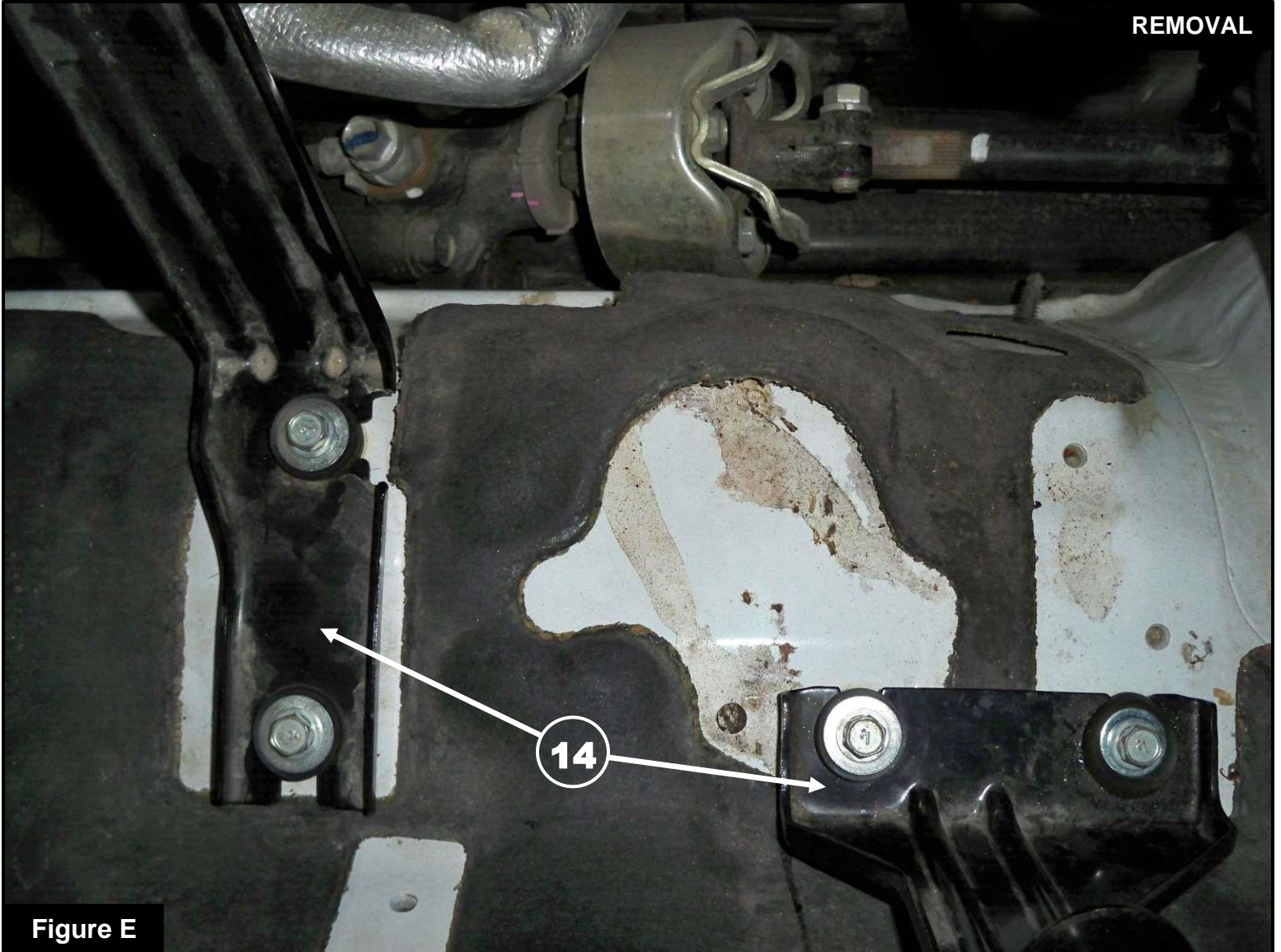

Figure E

Refer to Figure E for Step 6

Step 6: Using a 10mm socket and driver, remove the two mounting brackets (14) from the engine bay.



Figure F

Refer to Figure F for Steps 7-8

Step 7: Remove three of the rubber grommets and metal inserts (15) from the two mounting brackets and install them into the aFe POWER housing.

Step 8: Install the seal trim (16) on the top opening of the aFe POWER housing as shown. Trim to fit.

**Figure G****Refer to Figure G for Steps 9-10**

Step 9: To remove the vacuum reservoir, use a pair of pliers to slide the clamps on the three vacuum hoses.

Remove the vacuum hoses and expose the ports **17** as shown.

Step 10: Use a 10mm nut driver to remove the three screws **18** and remove the bracket with reservoirs from the vehicle.

Figure H

Refer to Figure H for Steps 11-13

Step 11: With the vacuum assembly out of the vehicle, move the left reservoir to the back-side of the bracket as shown.

Step 12: Remove the two screws (19) using a Phillips head screw-driver and move the reservoir (20) to the back of the bracket. Re-install the reservoir on the top most mounting points with the original screws.

Step 13: If the hose gets kinked/twisted after Step 12, use a pair of pliers to realign the vacuum hose (21) and properly seat it as shown.

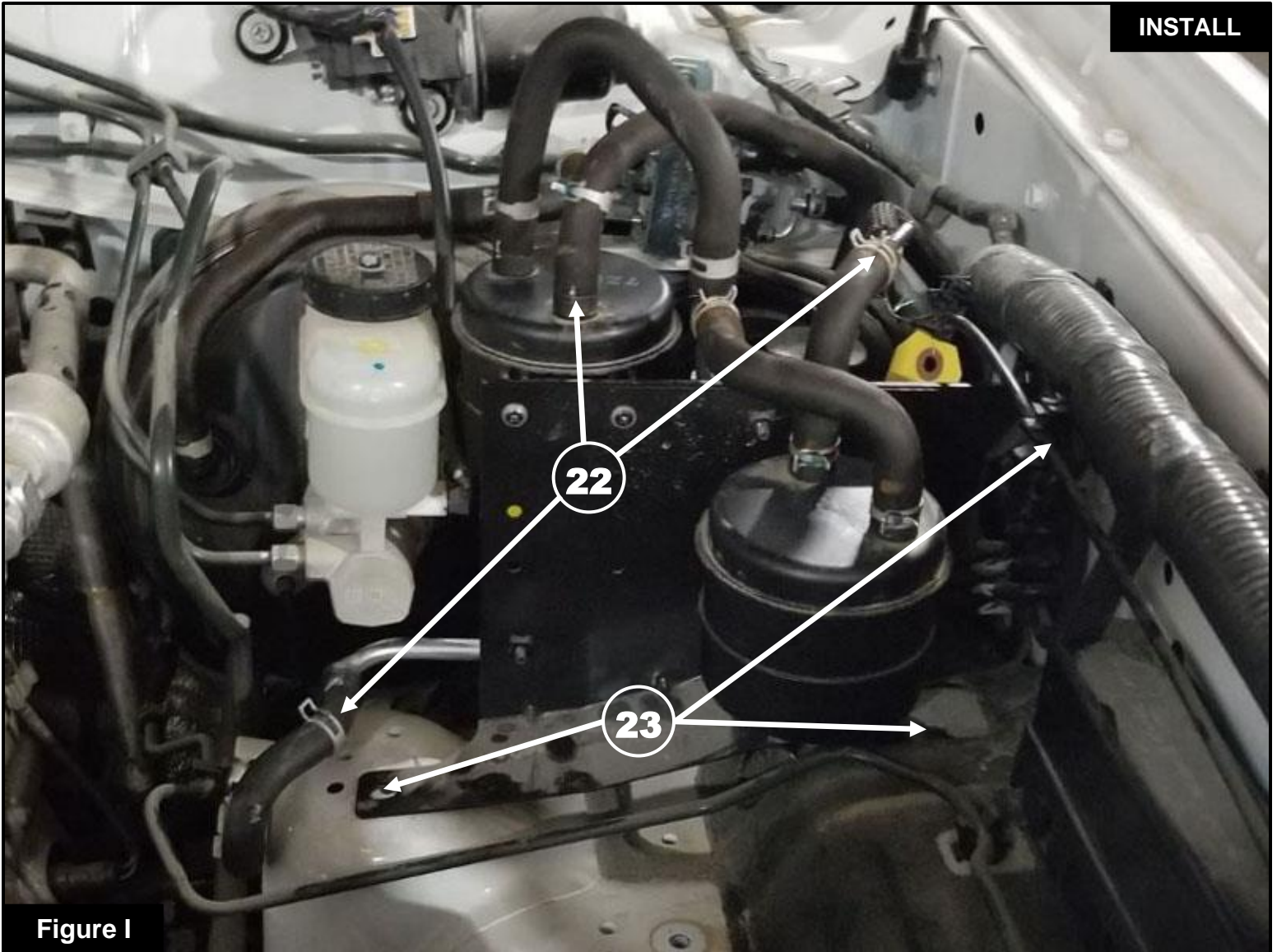

Figure I

Refer to Figure I for Steps 14-15

Step 14: Install the vacuum assembly back in the vehicle. Connect the three vacuum hoses (22) removed in Step 9 as shown. Secure them with their clamps using a pair of pliers.

Step 15: Re-install the three screws (23) holding the bracket down and tighten with a 10mm nut driver.

**Figure J****Refer to Figure J for Step 16**

Step 16: Using a 10mm socket and driver and three of the mounting bracket screws **24**, align and mount the aFe POWER housing to the frame. Tighten all three screws.



Refer to Figure K for Step 17

Step 17: Remove the filter clamp (25) from the aFe POWER filter. Slide the aFe POWER filter into the aFe POWER housing from the top. Then guide the filter flange through the round opening in the housing and snap in the filter. Place the filter clamp on the filter flange.

**Figure L****Refer to Figure L for Step 18**

Step 18: Install the silicone coupler on the throttle body with the supplied #048 clamp²⁶ as shown. Place the other supplied #048 clamp²⁷ on the silicone coupler. Do not tighten the clamps at this time.



Figure M

Refer to Figure M for Step 19

Step 19: Using the provided Security T-20 bit and driver, remove the mass air flow sensor (28) from the air cleaner assembly and install it on the aFe intake tube with the two supplied screws. Do not overtighten.



Figure N

Refer to Figure N for Steps 20-21

Step 20: Install the aFe POWER intake tube into the vehicle. Slide into the coupler coupler first then into the air filter. Tighten all clamps using an 8mm nut driver.

Step 21: Install the supplied vacuum hose connector (29) into the silicone coupler. Install the supplied vacuum hose into the intake solenoid valve and the vacuum hose connector. Install the vent hose tube (30) into the elbow port at the coupler.

**Figure O****Refer to Figure O for Steps 22-25**

Step 22: Reconnect the mass air flow sensor (31).

Step 23: Install the u-shape air duct (32) and push back the lock spring (33) to secure.

Step 24: Reinstall the engine cover.

Step 25: Check all the components are tight and secure. Your installation is now complete. Thank you for choosing aFe POWER!

NOTE: Check all bolts, clamps, and connectors after 100-200 miles.



Page left blank intentionally



advanced FLOW engineering, inc.

252 Granite Street Corona, CA 92879
TEL: 951.493.7100 • TECH: 951.493.7134
E-Mail: Tech@aFepower.com

P/N: 06-81449