

***advanced FLOW engineering***

Cold Air Intake System

**Instruction Manual** P/N: 56-70032D / 56-70032R

Make: Hyundai

Model: Kona

Year: 2018-2021

Engine: L4-1.6L(t)



- Please read the entire instruction manual before proceeding.
- Ensure all components listed are present.
- If you are missing any of the components, call customer support at 951-493-7185.
- Ensure you have all necessary tools before proceeding.
- Do not attempt to work on your vehicle when the engine is hot.
- Retain factory parts for future use.

Label	Qty.	Description	Part Number
A1	1	Air Filter (Pro 5R)	24-91153
A2	1	Air Filter (Pro DRY S)	21-91153
B	1	Tube	05-5670032B1
C	1	Housing	05-5670032B2
D	1	Coupling, Silicone Bellows Reducer	05-01594
E	1	Clamp, #044	03-50019
F	1	Clamp, #060	03-50002
H	2	Retainer Clips	03-50616

**Installation will require the following tools:**

8mm, 10mm, & 11mm socket, extension, ratchet, pliers and flat-head screwdriver

**Emissions Disclaimer:** This product is not currently CARB exempt and is not available for purchase in California or for use on any vehicle registered with the California Department of Motor Vehicles.

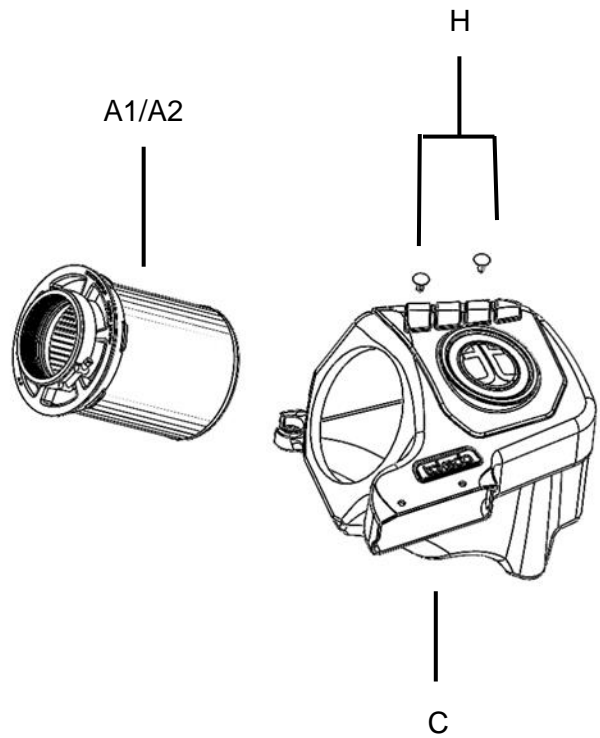
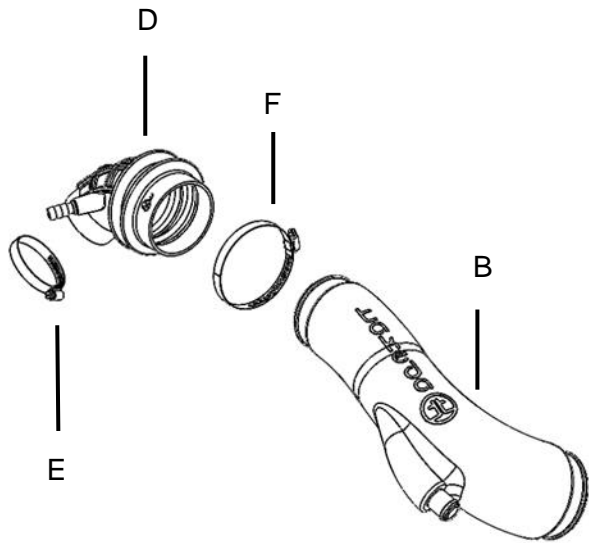

**Figure A****Refer to Figure A for Steps 1-4**

Step 1: Remove the engine cover by pulling upward on it.

Step 2: Using pliers, open the clamp securing the hose to the air intake tube, and then slide the clamp away from the intake tube. This clamp will be re-used. Disconnect the rubber hose from the air intake tube.

Step 3: Loosen the clamp securing the factory intake tube to the factory air box.

Step 4: Remove the two plastic rivets connecting the factory air inlet to the front of the car. Use a flat-head screwdriver to press down on the center of the rivet to unlock, and then pull them out. These plastic rivets will be replaced. Pull upwards on the factory air inlet to remove it from the vehicle.





Figure B

**Refer to Figure B for Steps 5-7**

Step 5: Using pliers, open the clamp securing the small hose to the air intake tube toward the firewall. Slide the clamps away from the tube, disconnect the small rubber hose from the intake tube. This clamp will be re-used.

Step 6: Loosen the clamp at the turbo inlet using a 10mm socket and ratchet.

Step 7: Remove the factory intake tube from the vehicle.

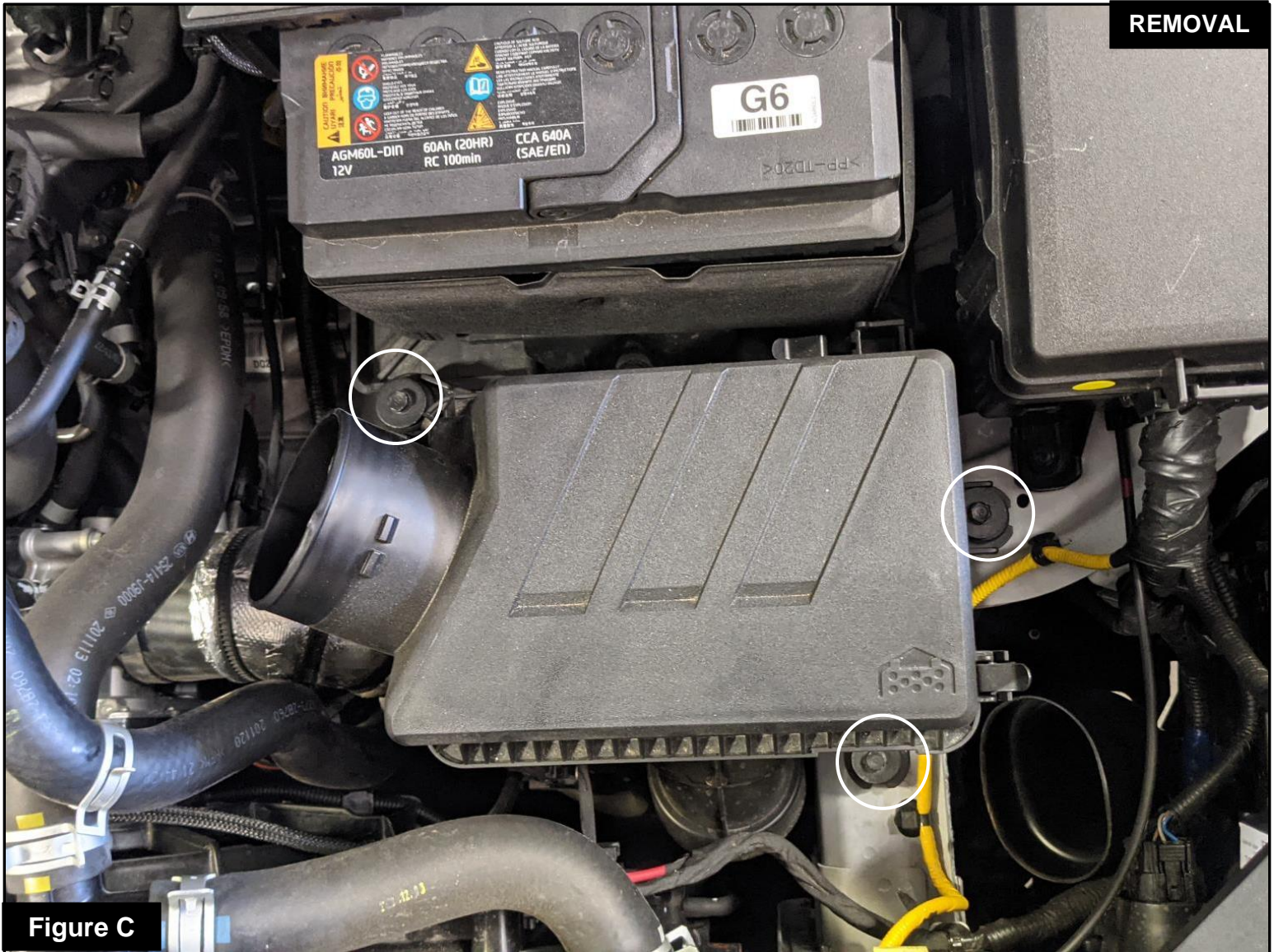

Figure C

**Refer to Figure C for Steps 8-9**

Step 8: With a 10mm socket, extension and ratchet, loosen the three bolts securing the factory housing to the vehicle. These three bolts will be re-used during the installation of the Takeda air intake system.

Step 9: Remove the bottom of the factory housing and air inlet as one piece out of the vehicle.



**Figure D****Refer to Figure D for Step 10**

Step 10: Transfer the three mounting grommets and sleeves from the bottom of the factory housing to the Takeda housing.



Figure E

**Refer to Figure E for Step 11**

Step 11: Install the Takeda housing into the vehicle. Secure it with the three bolts removed at Step 8. Two of the bolts will be installed inside the housing.





Figure F

**Refer to Figure F for Step 12**

Step 12: Install the air filter into the housing by firmly pushing it into the housing until the filter tabs lock it into place. Install on the clamp on the filter, but do not tighten at this time.



Figure G

**Refer to Figure G for Step 13**

Step 13: Secure the housing air inlet with the two provided plastic push rivets.



INSTALL

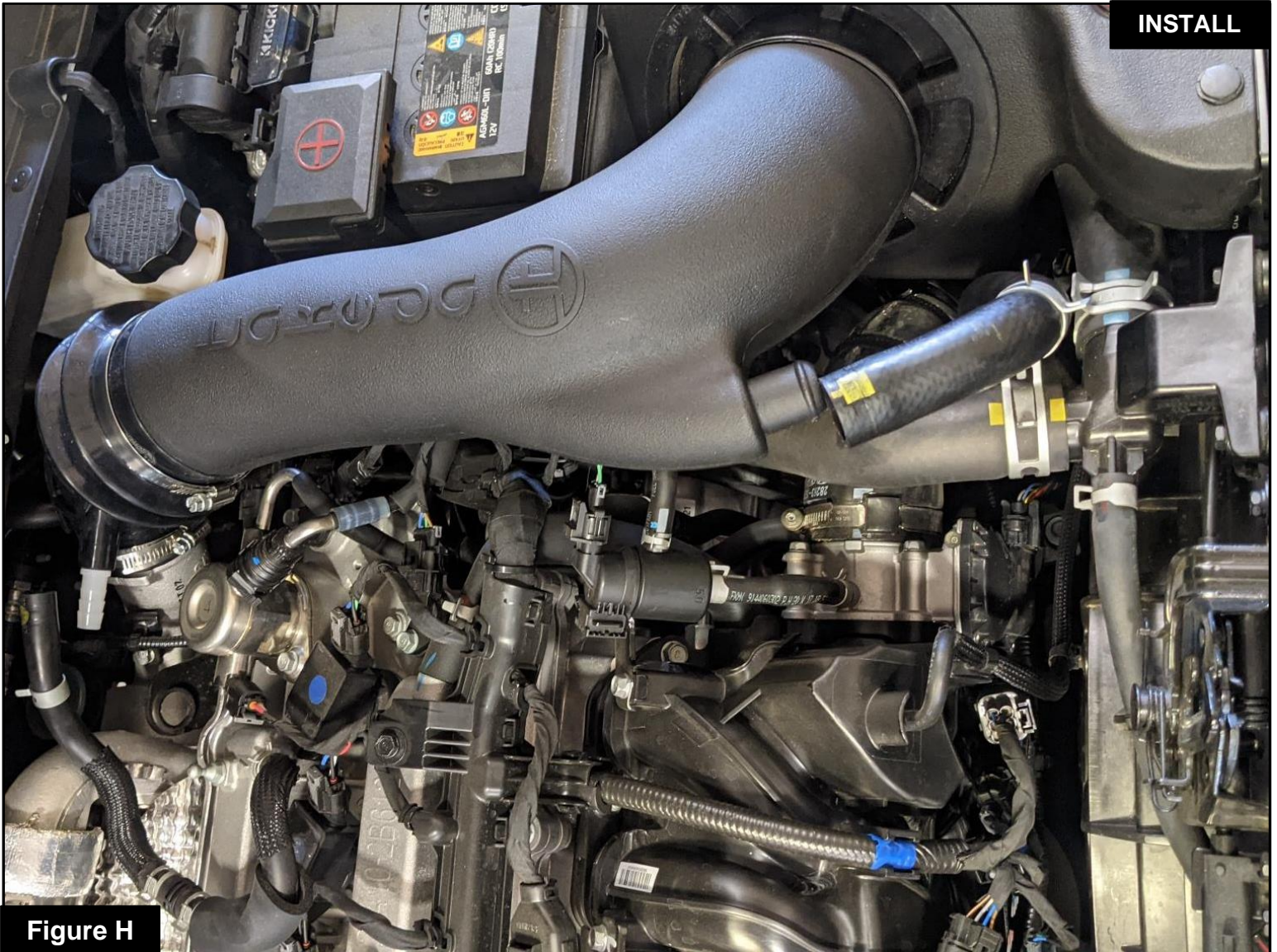

Figure H

**Refer to Figure H for Step 14**

Step 14: Install the coupling onto the smaller end of the tube. Install the provided clamps over the coupling, but do not tighten yet.





**Refer to Figure H for Steps 15-16**

Step15: Install the Takeda intake tube and coupling by sliding it over the turbo inlet, then into the air filter.

Step 16: Align the tube, filter and coupling then tighten all clamps.



**Figure I****Refer to Figure I for Step 17**

Step 17: Connect the small rubber hoses to the plastic fitting on the coupling. Secure it with the factory pry clamps.



**Refer to Figure J for Steps 18-19**

Step 18: Connect the bigger rubber hose to the Takeda air intake tube. Secure it with the factory pry clamp.

Step 19: Reinstall the engine cover.





**Figure K**

## **Refer to Figure K for Step 20**

Step 20: Make sure all clamps and connections are secured. Your installation is now complete. Thank you for choosing Takeda USA!

**NOTE:** Check all screws, clamps, and connectors are secure after 100-200 miles.



**Page left blank intentionally**



**Page left blank intentionally**





Pro DRY S Air Filter



P/N: 21-91153

Pro 5R Air Filter



P/N: 24-91153

Pre-Filter



P/N: 28-10053

Pro DRY S Restore Kit



P/N: 90-59999

Blue Squeeze Restore Kit



P/N: 90-50501

Tactical Backpack



P/N: 40-33205-B

Flashlight LED



P/N: 40-10202

Mechanic Gloves (L)



P/N: 40-10149

Scorcher GT Power Module



P/N: 77-47004

To purchase any of the items above, view airflow charts, dyno graphs, photos, and video; please go to [aFepower.com](http://aFepower.com).



# Warranty

## General Terms:

- aFe warrants their products to be free from manufacturer's defects due to workmanship and material.
- This warranty applies only to the original purchaser of the product and is non-transferrable.
- Proof of purchase of the aFe product is required for all warranty claims.
- Warranty is valid provided aFe instructions for installation and/or cleaning were properly followed.
- Proper maintenance with regular inspections of product is required to insure warranty coverage.
- Damage due to improper installation, abuse, unauthorized repair or alteration is not warranted.
- Incidental or consequential damages or cost, including installation and removal of part, incurred due to failure of aFe product is not covered under this warranty.
- All warranty is limited to the repair and/or replacement of the aFe part. To request Return Goods Authorization ("RGA"), email RGA@afepower.com or call (951)493-7100. Upon receipt of the RGA, you must return the product to the address provided in the RGA, freight prepaid and accompanied with a dated proof of purchase and the RGA. Upon receipt of the defective product and upon verification of proof of purchase, aFe will either repair or replace the defective product within a reasonable time, not to exceed thirty days.

Product Category	P/N Prefix	Warranty duration
Direct OE Replacement Filters	10, 11, 30, 31, 71, 73	Life of the vehicle
Racing Filters	18	1 year
Universal	20, 21, 23, 24, 72, TF	2 years
Air Intake Systems	50, 51, 53, 54, 55, 56, 57, 58, 75, TR, TA, TL, TM	2 years
Exhaust Systems	49	2 years
Intercoolers & Intercooler Tubes	46-2	2 years
Intake Manifolds	46-1	2 years
Differential Cover	46-7	Life of the vehicle
Exhaust Manifolds	46	2 years
Throttle Body Spacers	46-3	2 years
Turbochargers	46-6	2 years*
Fluid Filters	44	90 days
Pre-Filters	28	2 years
Heavy Duty OE Replacement	70	2 years
PowerSports OE Replacement	81, 87	2 years
PowerSports Intake Systems	85	2 years

No other warranty expressed or implied applies nor is any person or advanced FLOW engineering authorized to assume any other warranty. Some States do not allow the exclusion or limitation of incidental or consequential damages or do not allow limitations on how long an implied warranty lasts, so the above limitations or exclusions may not apply to you. This warranty gives you specific legal rights, and you may also have other rights which vary from State to State.

\*See turbocharger warranty for more info

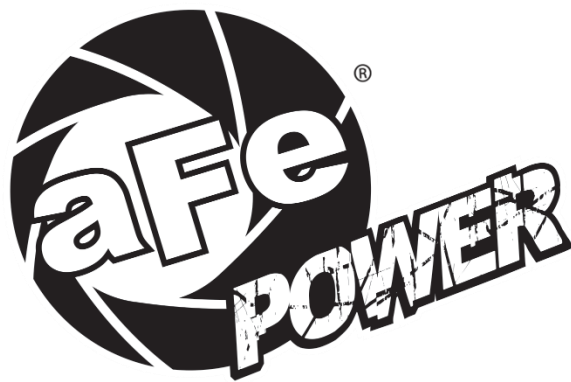

***advanced FLOW engineering, inc.***

252 Granite Street Corona, CA 92879  
TEL: 951.493.7100 • TECH: 951.493.7185  
E-Mail: Tech@aFepower.com