

**MOMENTUM** **HD**

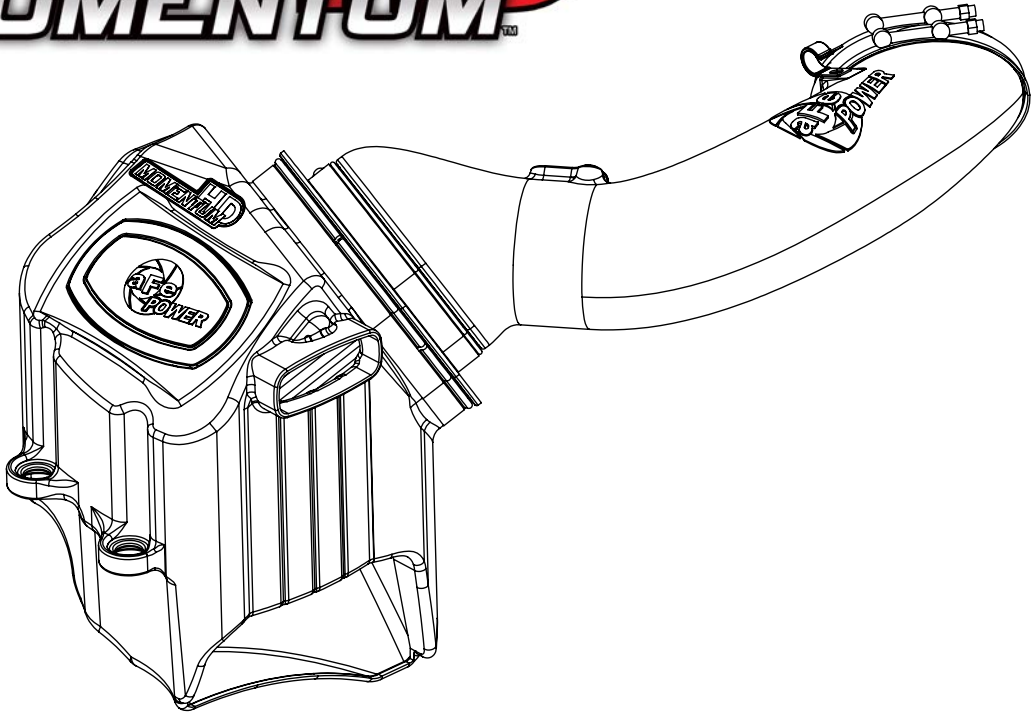

**advanced FLOW engineering** Momentum HD Cold Air Intake System

**Instruction Manual** P/N: 50-73006 / 51-73006

---

Make: **Ford** Model: **Super Duty F-250/F-350/F-450/F-550** Year: **2017-2019** Engine: **V8-6.7L (td) Power Stroke**



- Please read the entire instruction manual before proceeding.
- Ensure all components listed are present.
- If you are missing any of the components, call technical support at 951-493-7100 or e-mail [tech@afepower.com](mailto:tech@afepower.com).
- Ensure you have all necessary tools before proceeding.
- Do not attempt to work on your vehicle when the engine is hot.
- Disconnect both the negative battery terminal before proceeding.

## Retain factory parts for future use.

Label	Qty.	Description	Part Number
A1	1	Pro 10R (Blue Media)	20-91061
A2	1	Pro DRY S (Gray Media)	21-91061
B	1	Tube	05-73006B1
C	1	Housing	05-73006B2
D	1	Plug, Urethane	05-01225
E	1	Coupling, Silicone Hump	05-01204
F	1	Washer: M6	03-50070
G	2	Screw, Torx: M4	03-50491
H	1	Screw, Hex Hd: M6	03-50057
I	1	Fixing Clamp, 3/4"	03-50234
J	2	Clamp, T-bolt (4-13-16" - 5-1/8)	03-50261
K	1	Clamp, T-bolt (8-5/16" - 8-5/8")	03-50267
L	1	Harness, MAF Extension	05-70037

### Installation will require the following tools:

7mm, 8mm, 10mm, 7/16 nut driver or socket and extension.

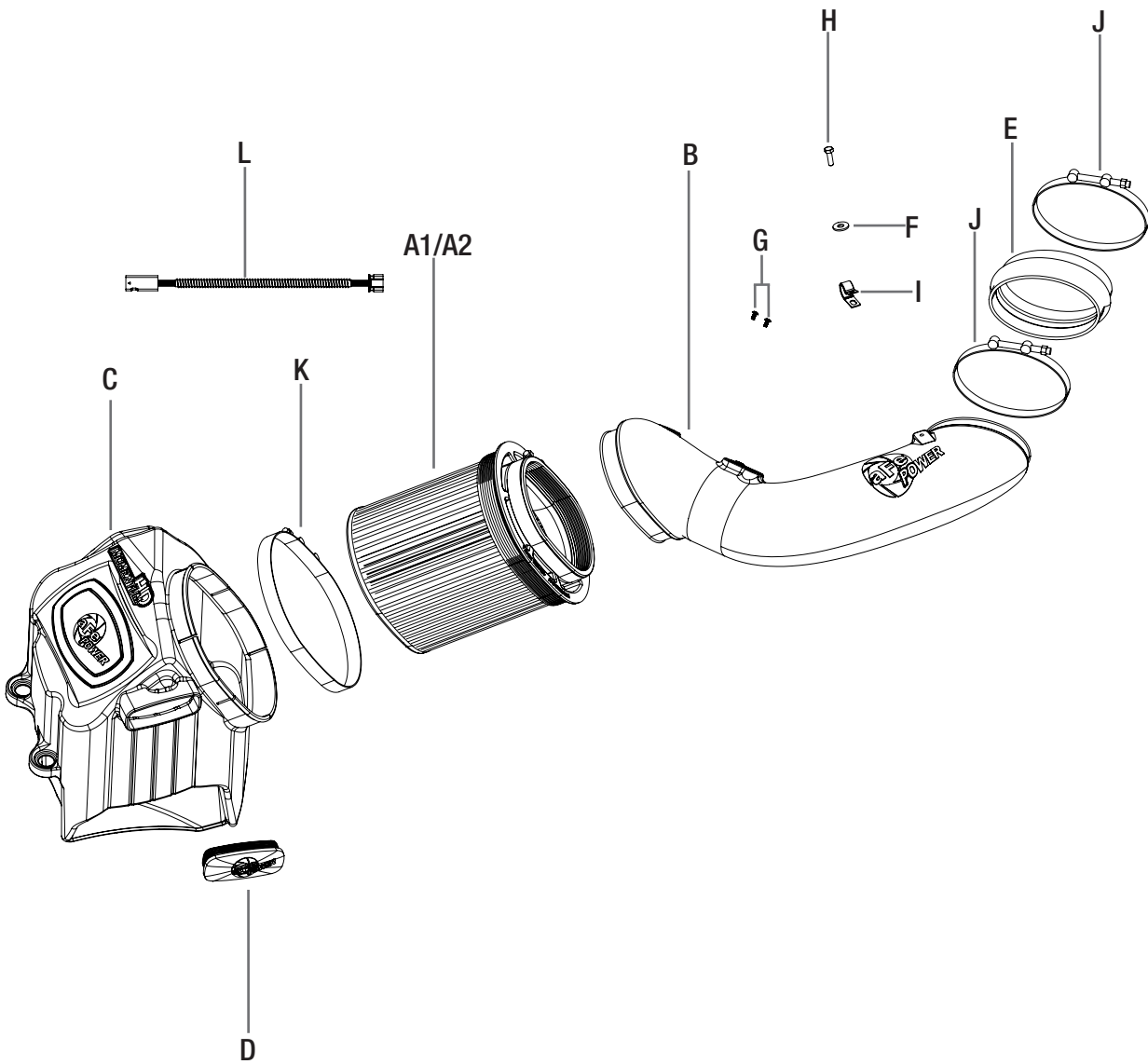



Figure A

**Refer to Figure A for Step 1**

Step 1: Remove the two 8mm bolts securing the OE filter housing, and loosen the two clamps on the OE tube.



Figure B

**Refer to Figure B for Step 2**

Step 2: Push the small hoses out of the way on the OE tube, and remove the tube.



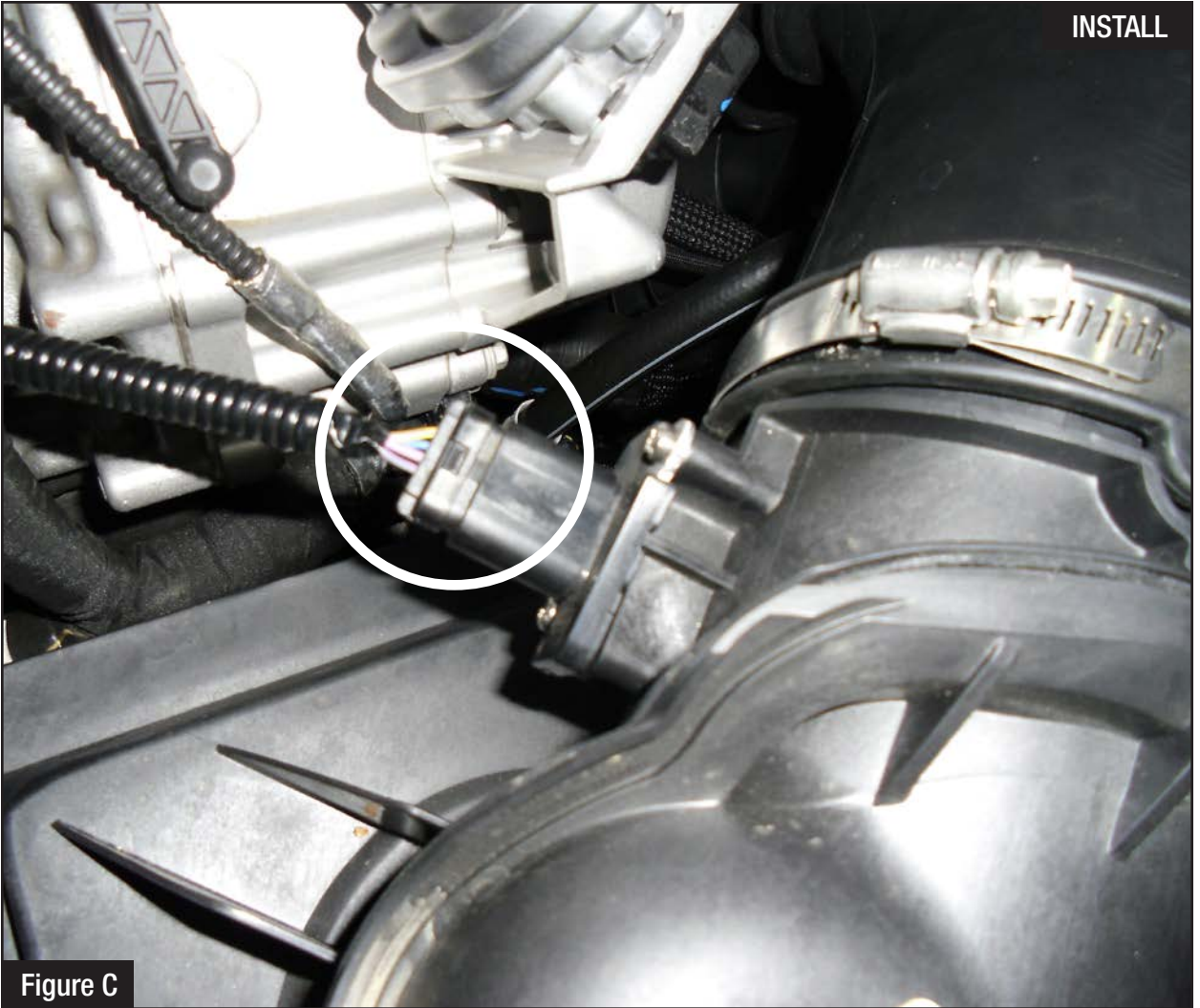

Figure C

**Refer to Figure C for Steps 3-4**

Step 3: Slide back the red locking tab on the bottom side of the MAF sensor connector, and then disconnect the sensor.

Step 4: Remove the OE air box, pulling in an upward motion.



Figure D

**Refer to Figure D for Steps 5-6**

Step 5: Remove the factory grommets from the OE air box and install on the Momentum HD housing.  
Step 6: Slide the filter into the housing and install provided T-bolt clamps. Tighten only the larger T-bolt clamp.



Figure E

**Refer to Figure E for Step 7**

Step 7: Install the Momentum HD housing into the vehicle by pushing it in to the factory grommet.





Figure F

**Refer to Figure F for Steps 8-10**

Step 8: Transfer the factory filter minder and grommet (1) on to the Momentum HD tube.

Step 9: Transfer the MAF sensor (2) from the OE housing to the Momentum HD tube using the provided screws.

Step 10: Install silicone coupling (3) and T-bolt clamps (4) onto the small end of the tube. Do not tighten clamps.



**Refer to Figure G for Steps 11-15**

Step 11: Install Momentum HD tube by first sliding the coupling over the turbo inlet. Connect the other end to the air filter.

Step 12: Tighten all clamps.

Step 13: Reconnect the MAF sensor (5). Using the provided MAF extension harness.

Step 14: Secure hose to the tube with provided fixing clamp (6), 10mm bolt (7) and washer (8).

Step 15: Reinstall the factory two 8mm bolts removed in Step 1 securing the air box.





Figure H

## **Refer to Figure H for Steps 16-18**

Step 16: If you have purchased the aFe air scoop (P/N: 54-73006-S), install it referring to its install instruction sheet.

Step 17: If you don't have the air scoop, you have the option to close off the extra air inlet with the furnished plug or to keep it open.

- Without the plug installed, the aFe Power intake will capture the maximum air available. More airflow offers more power. Yet some of this air is picked up from inside the engine compartment and could be warmer air. Warmer air will affect the performance of the vehicle.
- The plug installed on the housing will block off any hot engine air entering the housing and make sure the coolest air available is directed into the engine. It will also reduce the noise of the intake.

Step 18: Verify all connection are secured. The installation is now completed.

**NOTE: Place enclosed CARB EO sticker on or near the device on a smooth, clean surface. EO identification label is required to pass the smog inspection.**



Page left blank intentionally



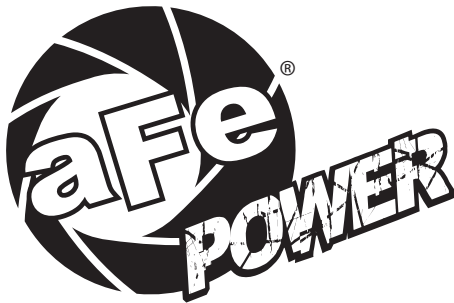

**advanced FLOW engineering, inc.**  
252 Granite Street Corona, CA 92879  
TEL: 951.493.7100 • TECH: 951.493.7134  
E-Mail: [Tech@aFepower.com](mailto:Tech@aFepower.com)