



INSTALLATION INSTRUCTIONS

MAKE: FORD

MODEL: F-250/350

YEAR: 2008-2010

ENGINE: V8-6.4L (td)

WHEELBASE: All except Cab & Chassis

**4" DPF-Back
49-43006**

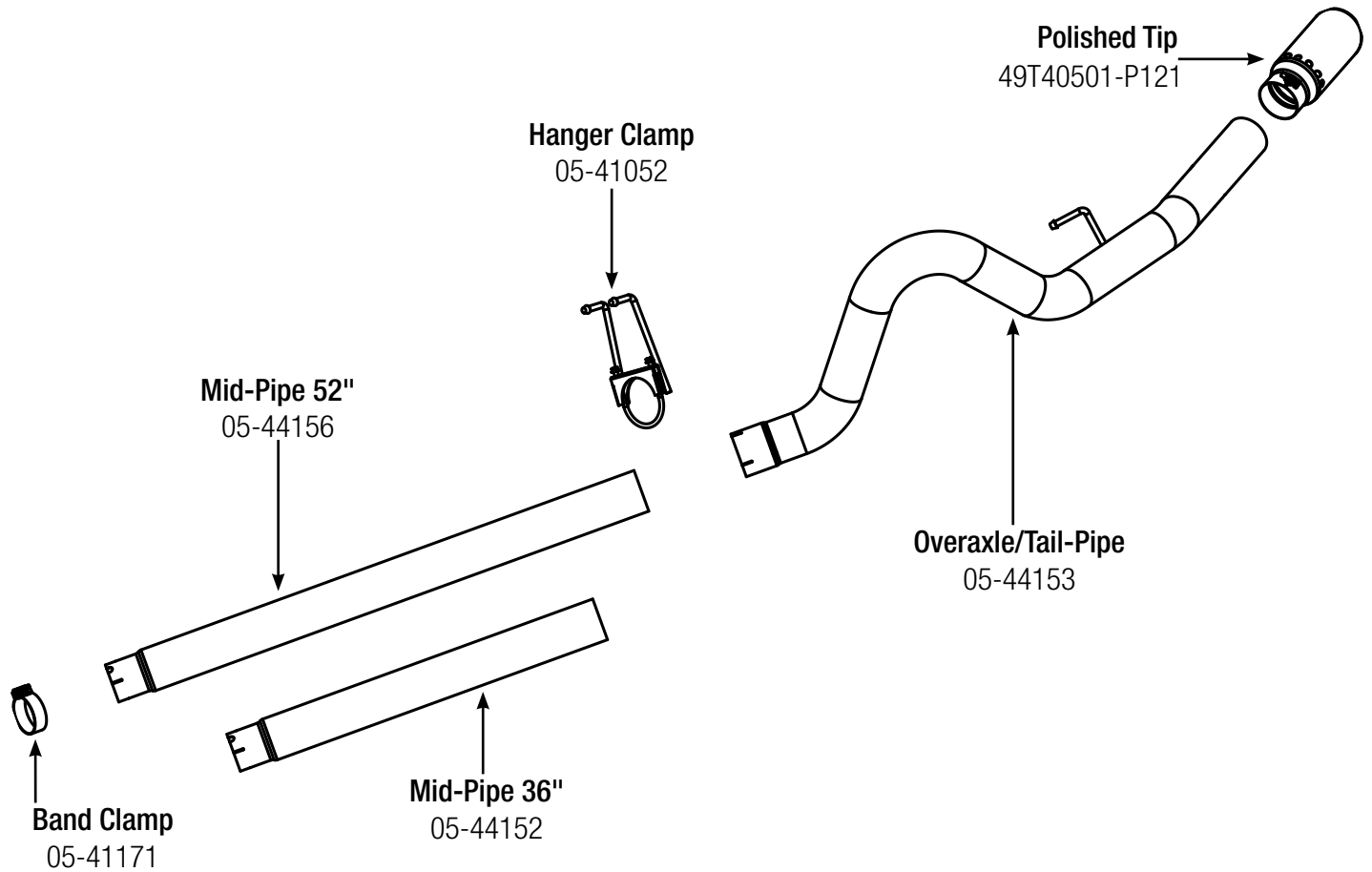

Step 1: (Read Instructions prior to installation) Remove the stock exhaust from the rear of the truck working your way forward. The spare tire and heat shield will need to be removed for exhaust replacement. Take caution not to damage the factory isolation mounts as they will be reused. **It is recommended to not fully tighten the clamps until the entire system has been installed.**

Step 2: For faster installation spread the pieces of the exhaust along side of your vehicle according to the diagram shown.

Step 3: Install overaxle/tail-pipe, utilizing the factory isolation mounts. Now slip the middle hanger clamp over the front end of overaxle/tail-pipe.

Step 4: Now install the mid-pipe, regular cab and quad cab short bed will require the short mid-pipe. Crew cab long bed will use the long mid-pipe.

Step 5: Install the exhaust tip, adjust for alignment and tighten all connections. Re-install the spare tire and heat shield. The valve on the spare tire should be pointing down to allow for better access. Your installation is now complete. It is recommended to re-tighten all exhaust components after the first 50-100 miles.

NOTES:

- aFe recommends that the tail-pipe be at least 1/2"-1" away from any body panels to avoid heat related body damage. **Tighten and secure.**

Caution: Allow time for your vehicle to cool down prior to installation. When working on or under your vehicle proceed with caution. Exhaust systems reach high temperatures and may cause serious burns. Wear protective safety equipment; eye goggles and gloves to ensure a safe installation. **aFe recommends professional installation on our products.**