



252 Granite St, Corona, CA 92879
PH (844) 469-6827
www.aFeControl.com

2004-2015 Nissan Titan Front Coilover Kit Installation

Parts List

-2 Sway-A-Way Coilover Shocks

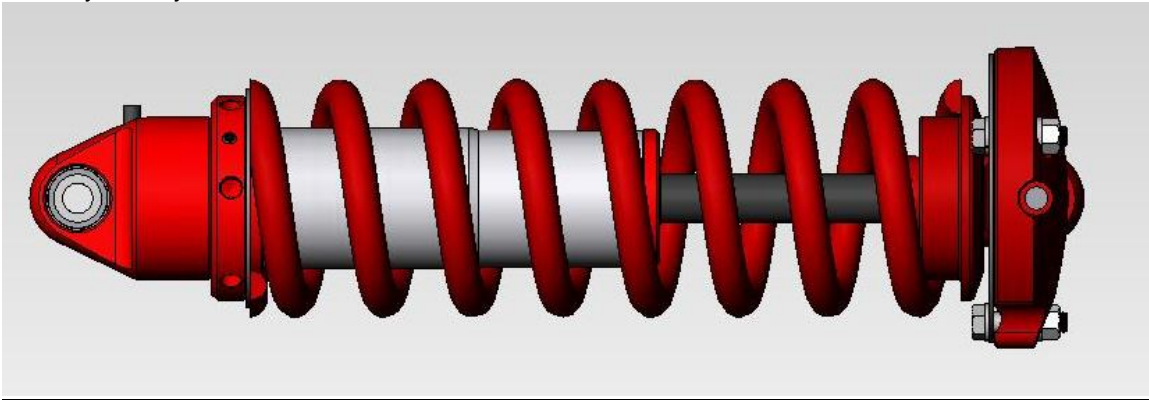

Tool List

-5/32" Allen wrench
-3/8" Allen wrench
-9/16" wrench and socket (Sway-A-Way spring hat)
-14mm wrench or socket (OEM spring hat)
-19mm wrench and deep socket (Lower front shock bolt and OEM U-Bolts)
-21mm socket (lug nuts)
-Jack and jack stands

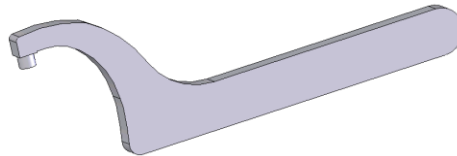

-Spanner wrench (included)

-Impact wrench (optional)

Removal and Installation Procedure for Titan Front (Shocks come pre-charged direct from the factory with Nitrogen)

1. Park the vehicle on a level concrete surface where it is safe to work on your vehicle.
2. Lock and center the steering wheel.
3. Place blocks in front and behind the rear tires so as to keep the vehicle from moving forwards or backwards.
4. **It is beneficial that you get a reference measurement of the stock ride height prior to the removal of the stock coil-overs;** measuring the distance from the center of the hub to the bottom of the fender does this. You will use this measurement when you are setting your ride height after installation.
5. Using a jack lift the front of the vehicle and support the vehicle using jack stands. Be sure to place the jack and jack stands securely in the positions shown in the diagram. After placing the jack stands slowly lower the jack and remove the jack so that the front suspension can hang freely. Remember to be alert and cautious when working under a vehicle.

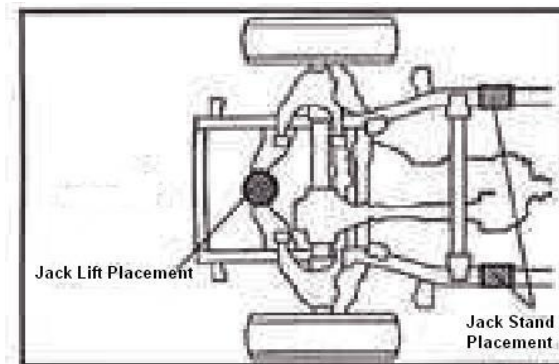

6. Remove the front wheels and set them aside.
7. Using a **14mm** wrench or socket remove the three nuts from the top of the OEM spring hat.



8. Using a **19mm** wrench and socket remove the bolt (19mm) and nut (19mm) from the lower shock mount. Remove the entire shock assembly from the truck. Remember to save the lower shock mount bolt and nut

9. To install your new *Sway-A-Way* shocks, remove the upper shock mount from the shock and assemble on the frame. The new shock mount will mount on top of the original coil bucket, with the notches facing towards the engine compartment. The laser cut back-up ring goes on the underside of the coil bucket. Using the supplied 3/8" bolts, washers, lock-washers and nuts assemble upper shock mount onto the coil bucket. Use three lock washers on the nut side and use the ring with three holes and the rest lock washers on the bolt head side. The head of the bolt facing down.

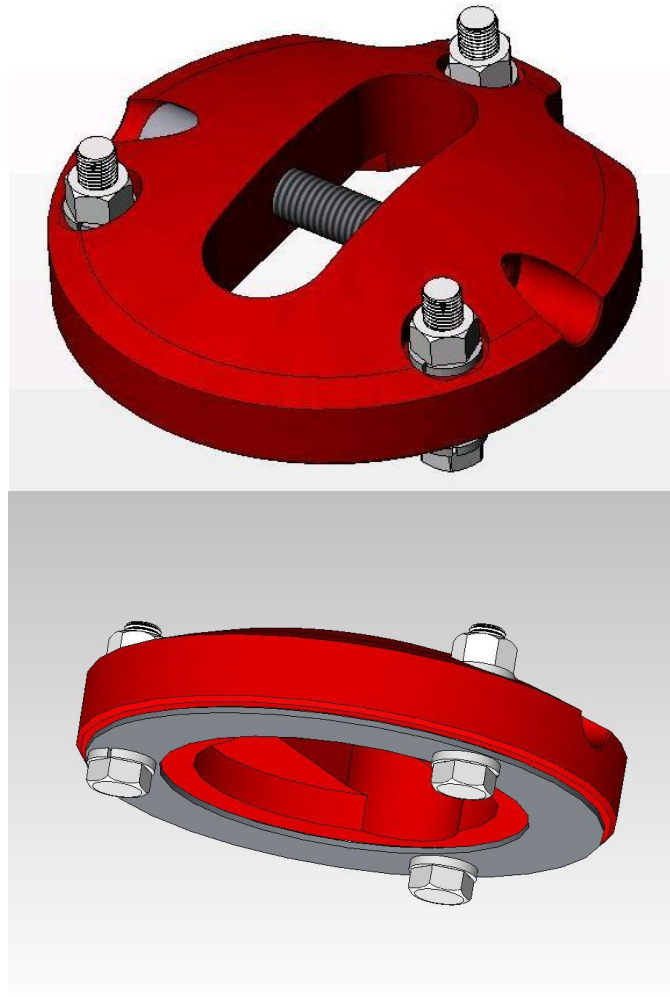

10. Using a **9/16"** wrench and socket torque the new spring hat 3/8" bolts to 50ft-lbs.

11. With the upper mount secured, install shock as supplied in kit, with the shaft and rod end up, and the Schrader valve facing outwards. Tighten down the upper mount bolt with a 3/8" allen wrench and torque to 85ft-lbs.

12. Using a **19mm** wrench and socket secure the shock to the lower arm utilizing the stock bolt and nut as well as the special provided bearing spacers. (Ensure that the Schrader valve is facing outboard towards the tire, you may have to pry the lower arm down some to line up the shock eyelet with the lower mount).

Make sure large spacer is towards the rear

13. Torque the lower shock mount bolt to 85ft lbs using a **19mm** wrench and socket.
14. Repeat steps 6 to 13 for the removal and installation of shock on other side.
15. When you are done installing the coil-overs, check for clearance. Turn the wheel to full lock right and left to ensure no binding or fitment problems. On 4-wheel drive models, ensure the top cap clears the axle of the driveshaft.
16. Replace the wheels. Tighten the lug nuts to factory torque specifications and set the vehicle on the ground. Inspect the ride height.
17. If you are happy with the achieved lift you are done. If the lift is too much loosen the coil spring adjuster. If the lift is not enough tighten the coil spring adjuster. Repeat until you have achieved the desired lift. Remember to loosen setscrew and lift the vehicle back up with a jack if adjusting the height and also to tighten the setscrew when all adjusting has been completed. Based on vehicle weight and packages, the amount of pre-load is different from vehicle to vehicle. The distance from the adjuster-nut to the top cap (amount of thread showing) should be no more than 2".

**The maximum amount of lift recommended for a 2WD is 3"
The maximum amount of lift recommended for a 4WD is 2.5"**

After you have finished installing your suspension kit, you must have the front end aligned.