



FITTING INSTRUCTIONS

Part Numbers: **2840040 – RECOVERY POINT**

Suited to vehicle/s: **FORD RANGER 2011 ONWARDS**

WARNING

NOTE THE FOLLOWING:

- ◆ This product must be installed exactly as per these instructions using only the hardware supplied.
- ◆ In the event of damage to any recovery point component, contact your nearest authorised ARB stockist. Repairs or modifications must not be attempted.
- ◆ Do not use this product for any vehicle make or model, other than those specified by ARB.
- ◆ Do not remove labels from this recovery point.
- ◆ This product or its fixing must not be modified in any way.
- ◆ The installation of this product may require the use of specialized tools and/or techniques
- ◆ It is recommended that this product is only installed by trained personnel
- ◆ These instructions are correct as at the publication date. ARB Corporation Ltd. cannot be held responsible for the impact of any changes subsequently made by the vehicle manufacturer
- ◆ During installation, it is the duty of the installer to check correct operation/clearances of all components
- ◆ Work safely at all times
- ◆ Unless otherwise instructed, tighten fasteners to specified torque

ARB 4x4 ACCESSORIES

Corporate Head Office

42-44 Garden St
Kilsyth, Victoria
AUSTRALIA 3137

Tel: +61 (3) 9761 6622
Fax: +61 (3) 9761 6807

Australian enquiries
North & South American enquiries
Other international enquiries

sales@arb.com.au
sales@arbusa.com
exports@arb.com.au

www.arb.com.au

IMPORTANT INFORMATION

GENERAL CARE AND MAINTENANCE

By choosing an ARB Recovery Point, you have bought a product that is one of the most sought after 4WD products in the world. Your recovery point is a properly engineered, reliable, quality accessory that represents excellent value. To keep your recovery point in original condition it is important to care and maintain it following these recommendations:



As part of any Pre Trip Preparation, or on an annual basis, it is recommended that a thorough visual inspection of the recovery point is carried out, making sure that all bolts and other components are torqued to the correct specification. Replace any components as necessary. This service can be performed by your local authorised ARB Stockist.

FITTING REQUIREMENTS

REQUIRED TOOLS FOR FITMENT OF PRODUCT:

BASIC TOOL KIT	TORQUE WRENCH 44Nm
AIR SAW/MULTI TOOL	SIDE CUTTERS
STRAIGHT CUT AVIATION SNIPS	3/8 EXTENSION (>150mm)

HAVE AVAILABLE THESE SAFETY ITEMS WHEN FITTING PRODUCT:

Protective eyewear	
Hearing protection	

NOTE: 'WARNING' notes in the fitting procedure relate to OHS situations, where to avoid a potentially hazardous situation it is suggested that protective safety gear be worn or a safe work procedure be employed. If these notes and warnings are not heeded, injury may result.

FASTENER TORQUE SETTINGS:

SIZE	Torque Nm	Torque lbft
M6	9	7
M8	22	16
M10	44	32
M12	77	57

PARTS LISTING – FITTING KIT 6173921

APPLICATION	PART NO.	QTY.	DESCRIPTION
RECOVERY POINT	3759709	1	WELD ASSY RECOVERY POINT
RECOVERY POINT TO CHASSIS	3752118	1	BRKT RECOVERY POINT PXIII
	3759081	2	ASSY WELD NUT – SINGLE
	4654140	1	ASSY WELD NUT – SMALL (REAR)
	4654141	1	ASSY WELD NUT – LARGE (FRONT)
	4584333	3	WASHER SPACER DIA 35MM X 8MM
	4721772	1	HOSE 8MM ID x 1.5 MM WALL X 150 MM
	180302	2	CABLE TIE 4.8 MM X 200 MM
	6151232	3	BOLT M10 x 1.5 x 30 Gd 8.8 ZP
	6151204	4	BOLT M10 x 1.5 x 35 Gd 8.8 ZP
	6151456	2	BOLT M10 x 1.5 x 45 Gd 8.8 ZP
	4584361	11	WASHER M10X25X4 ZP
	6151321	2	NUT FLANGE M10 x 1.5 ZP
FITTING	3195020	1	PLATE RP TORQUE RANGER/BT50
SAFETY	2125484	1	RECOVERY POINT WARNING LABEL (SPARE)
	211433	1	VEHICLE RECOVERY BOOKLET
	211512	1	OPERATOR INSTRUCTION CARD

VEHICLE PREPARATION

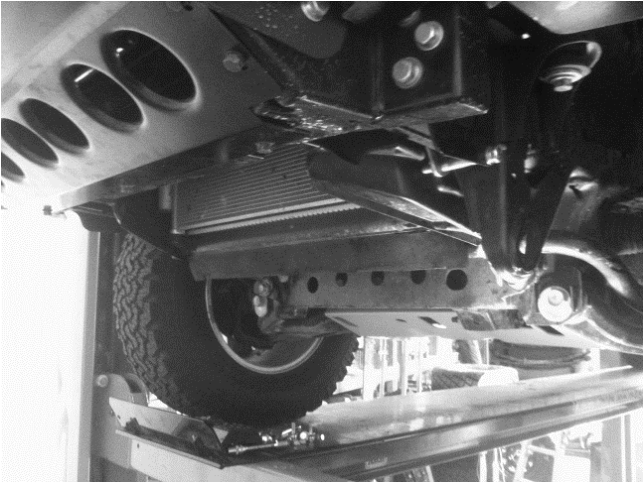

1. Remove stone shield or under body protection as shown, if fitted.

NOTE:

Retain all fasteners as these will be reused later.

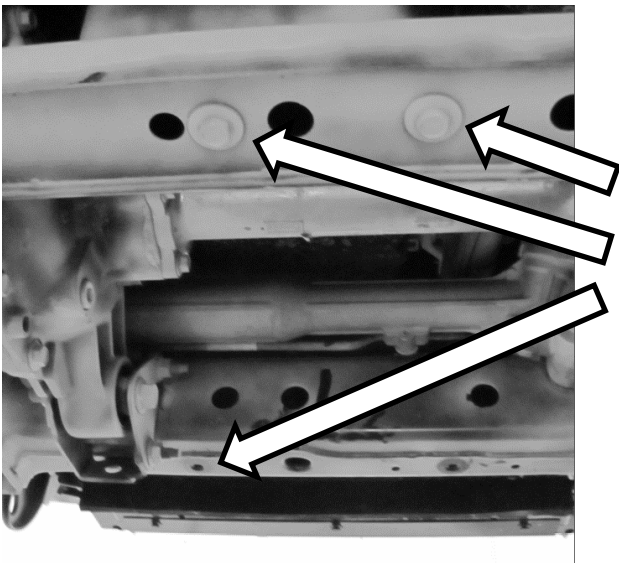

2. Check all captive nuts for damage or wear. Check all 3 captive nuts are free from any foreign material.

IMPORTANT:

DO NOT FORCE BOLTS INTO NUTS.

Spray lubricant into these captive nuts and test thread is clear.

NOTE:

If required repair holes using an \varnothing M10 X 1.5 tap or seek assistance from your local ARB service centre.

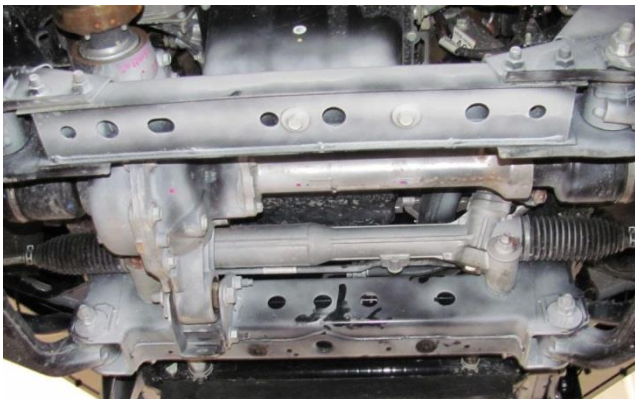

3. Inspect front and rear cross members for any damage or deformation.

IMPORTANT:

If either is visible, consult your nearest ARB service centre for advice.

FITTING PROCEDURE



NOTE:

STEPS 4,5,7&23 are only required for vehicles with Hydraulic Power Steering (HPS) (PX Ranger/BT-50 (2011-2015))

4. Remove the two power steering line bolts from the top of the front cross member as shown.

NOTE:

Keep these fasteners as these will be reused later.

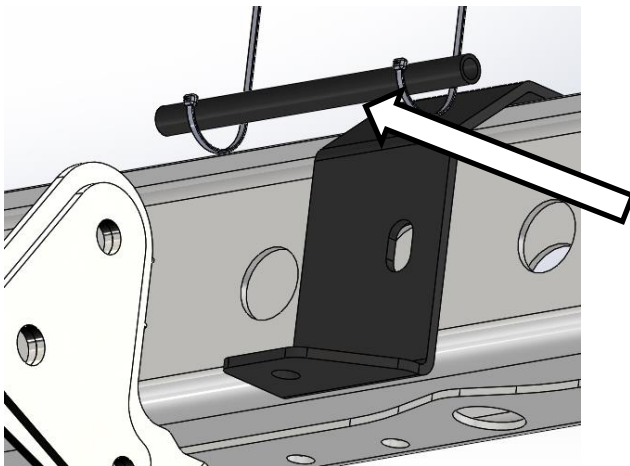

5. Use straight cut aviation snips to slit the 150 mm length of rubber hose. Fit over the power steering return line and cable tie each end with the slit facing upwards. Trim cable ties with side cutters.
6. Place UPPER CHASSIS BRACKET on top of chassis as shown. For vehicles fitted with HPS ensure the bracket is between the rubber hose (power steering return line) and the chassis as shown.

IMPORTANT:

Do not bend the power steering return line. Loosen retaining nuts for fitment if required. Reattach in reverse order after upper bracket installation.



7. Place washers under both power steering line mount positions and reattach using bolts removed in STEP 4 finger tight only.

FITTING PROCEDURE



IMPORTANT:

Only finger tighten bolt unless otherwise specified. Torque Sequence is important for part function.

8. Place the recovery point into position and align the bottom hole. While holding the recovery point firmly against the chassis, fasten an \varnothing M10 x 35 mm bolt and washer into the bottom hole of the recovery point.

Note: Finger tight only

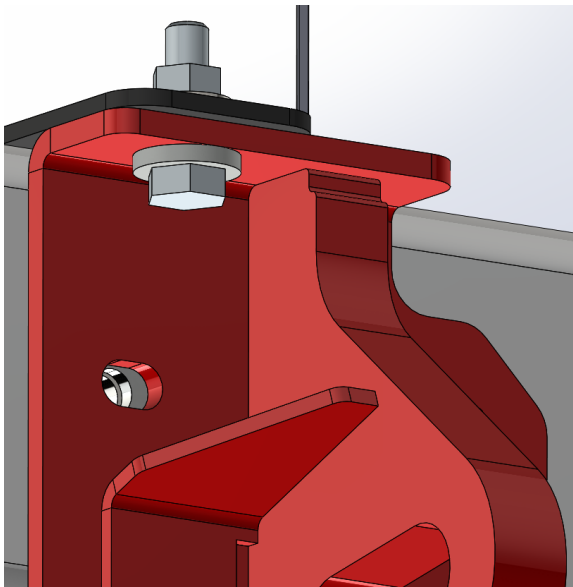

9. Fasten the front of the top bracket to the recovery point using \varnothing M10 x 30 mm bolt, flat washer and flange nut as shown finger tight only.

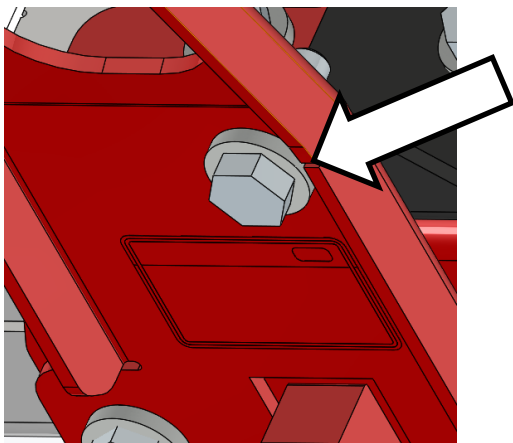

10. Attach the bottom of recovery point to the upper bracket with \varnothing M10 x 30 mm bolt, flat washer and a flange nut finger tight only.

FITTING PROCEDURE

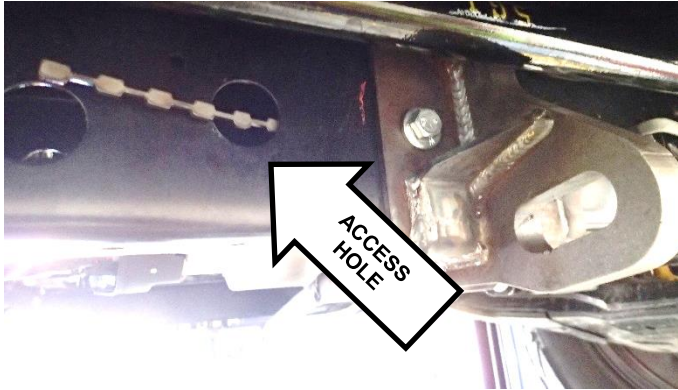

11. Insert the larger weld nut plate through the front access slot on the right (driver) side of the front cross member.

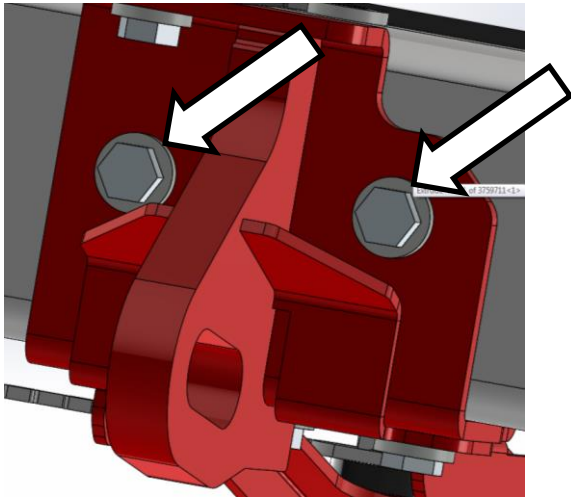

12. Fit \varnothing M10 x 35 mm bolt and flat washer to both front bolt holes finger tight only as shown.

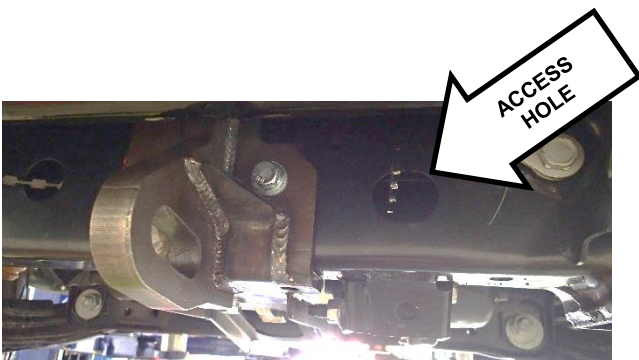

13. Insert the small weld nut plate through the front access slot on the left (passenger) side of the front cross member.

Note: Place flat side of weld nut plate to rear of vehicle.

FITTING PROCEDURE

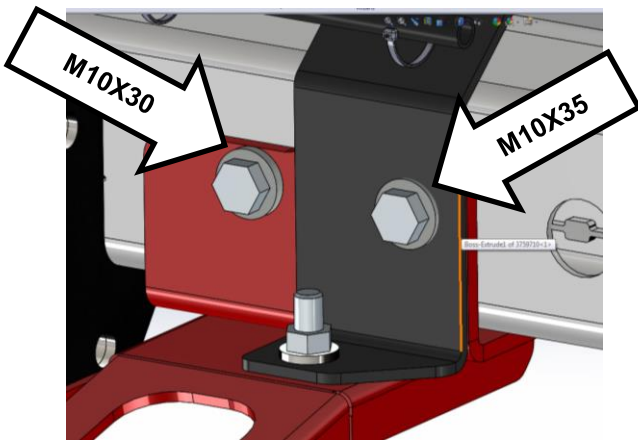

14. Fit \varnothing M10 x 30 mm bolt and flat washer to LHS and M10 x 35 mm bolt and flat to RHS holes finger tight only as shown.

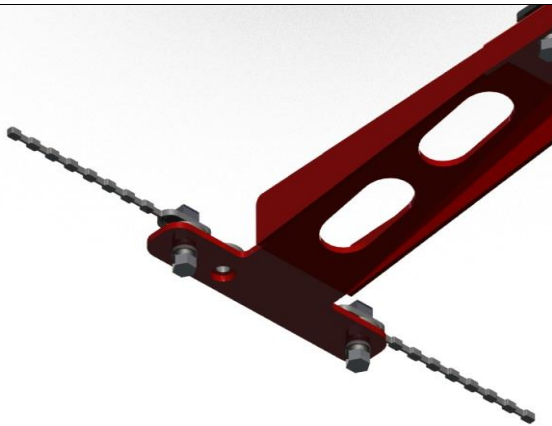

15. Insert weld single nut plates through access hole in top of the rear cross member.
16. Place \varnothing 35 mm x 8 mm spacer washers above each hole on the rear of the recovery point.
17. Fit \varnothing M10 x 45 mm bolt and flat washer to both outside holes finger tight only as shown.

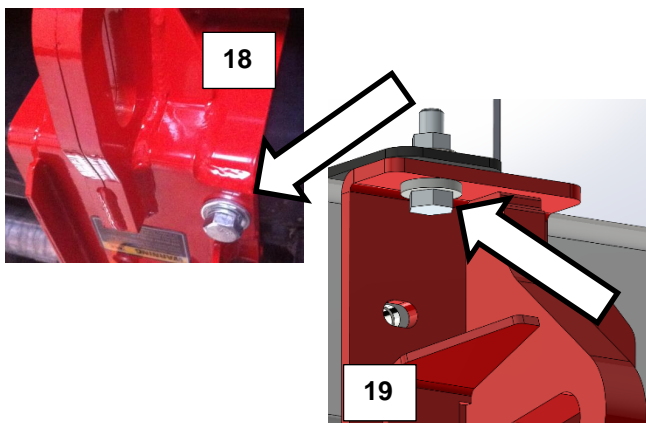



IMPORTANT:



**DO NOT USE IMPACT WRENCH
& DO NOT EXCEED TORQUE
SPECIFICATION.**

Torque Sequence is important for part function.

\varnothing M10 fasteners,  **44 Nm.**

18. Torque bolting point fitted in **step 8** to  **44 Nm.**
19. Torque bolting point fitted in **step 9** to  **44 Nm.**

FITTING PROCEDURE

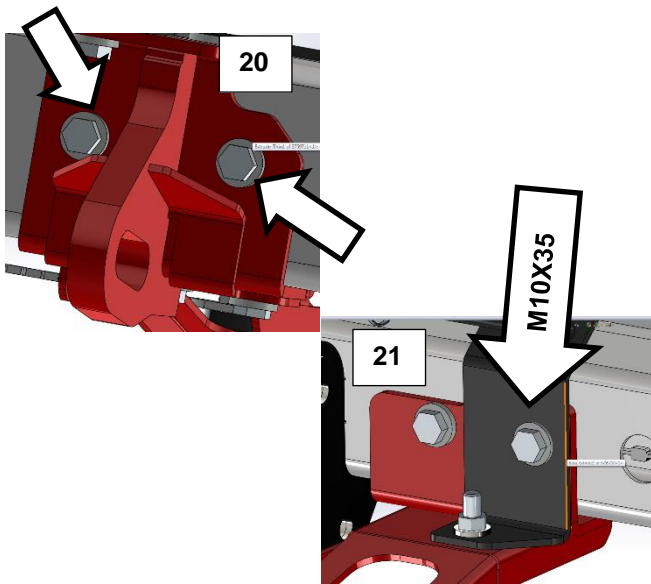

20. Torque bolting point fitted in **step 12** to  **44 Nm.**

21. Torque M10X35 bolt fitted in **step 14** to  **44 Nm.**

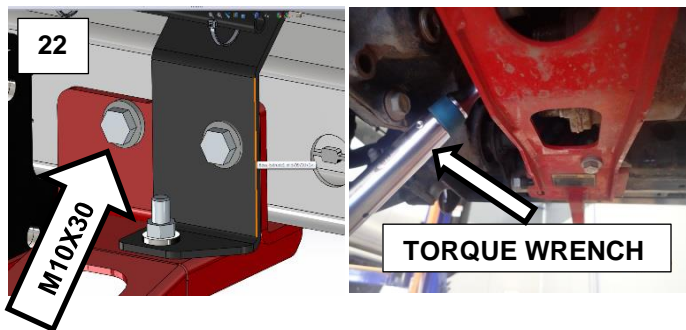

22. For vehicles fitted with HPS torque M10X30 bolt fitted in **step 14** to  **44 Nm.**

For vehicles **not** fitted with HPS use supplied torque plate (3195020), 3/8 extension and torque wrench.

Ensure torque wrench remains collinear to torque plate as shown in the picture A on the left. Do not allow the torque plate and torque wrench to rotate out of place as shown in picture B.

Using length of torque wrench set torque setting as below and tighten bolt to specification:

- 200mm – 37Nm
- 250mm – 38Nm
- 300mm – 39Nm
- 350mm – 39Nm
- 400mm – 40Nm
- 450mm – 40Nm
- 500mm – 41Nm
- 550mm – 41Nm
- 600mm – 41Nm



FITTING PROCEDURE

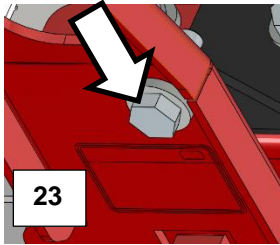

23. Torque bolting points fitted **in step 10** to

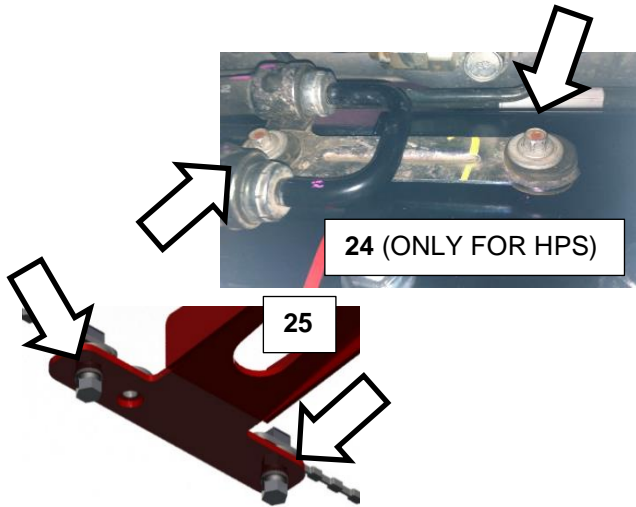

24. Fasten power steering lines to manufactures specification. (*Only for vehicles fitted with HPS*)

25. Torque bolting points fitted **in steps 17** to

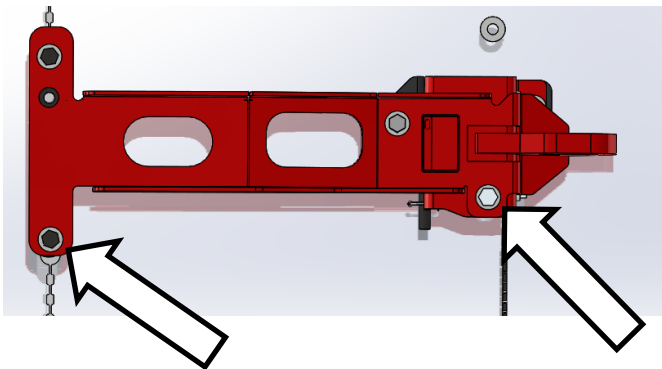

26. Bolt in LWR side of FRT Cross member and REAR LHS bolts need to be removed to reinstall stone shield.

NOTE:

Refit stone shield fasteners supplied with recovery point.

27. Refit stone shield to vehicle in reverse order to removal.

NOTE:

Some trimming to the factory stone shield may be required.

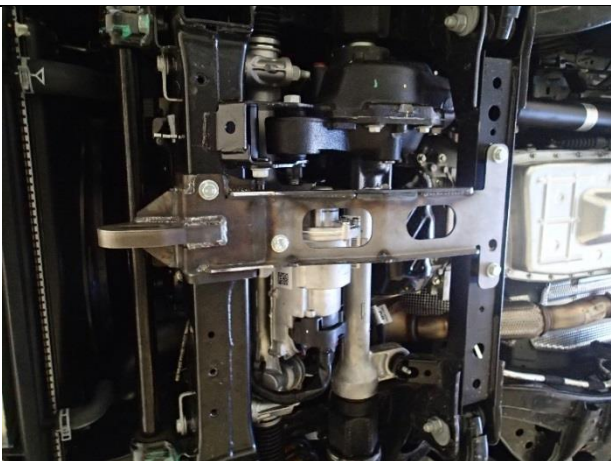

28. Finished product fitted to vehicle (stone shield not shown).

29. Attach the spare recovery point warning sticker in an easy to read position (I.e. The top pan on the bullbar) on the vehicle.