



INSTALLATION MANUAL
VENGEANCE REAR BUMPER
PRODUCT NUMBER: E4551
APPLICATION: 2021 DODGE TRX



IMPORTANT SAFETY GUIDE | Your safety and the safety of others is very important.

In order to help you make informed decisions about safety, we have provided the following warnings, safety precautions, installation instructions, and other important information to alert you to potential hazards that could hurt you or others.

Please do a job safety analysis before each task to identify potential hazards for your situation and remove/protect against them. Use own good judgment and take your time.

Check packaged materials immediately upon arrival to ensure that all listed parts are included and undamaged.

Read and understand all warnings, safety precautions, and instructions before installing this product.

SENSORS FIELD OF VIEW MAY BE ALTERED WITH USE OF THE REPLACEMENT BUMPER.

WARNINGS

- Failure to observe the following warnings and instructions provided in this manual could lead to severe injury and/or death.
- For professional installation only. Careless installation and/or operation can result in serious injury, death, and/or equipment damage. All liability for installation and use rests with the user or consumer.
- Fab Fours, Inc. only approves installing this product according to these written instructions with the hardware provided. Failure to install according to these instructions will invalidate the warranty. This includes, but is not limited to, using alternative installation methods, hardware, or materials.
- This product is for off road use only.

SAFETY PRECAUTIONS

- Always remove jewelry and wear eye protection.
- Always use extreme caution when jacking up a vehicle for work. Set emergency brake and use tire blocks. Locate and use the vehicle manufacturers designated lifting points. Use jack stands.
- Always use appropriate and adequate care in lifting components into place.
- Always ensure components will remain secure during installation and operation.
- Always wear safety glasses when installing this kit. A drilling operation will cause flying metal chips. Flying chips can cause serious eye injury.
- Always use extreme caution when drilling a vehicle. Always disconnect power before welding. Thoroughly inspect the area to be drilled (on both sides of material when possible) prior to drilling, and relocate any objects that may be damaged.
- Always use extreme caution when welding a vehicle. Thoroughly inspect the area to be welded (on both sides of material when possible) prior to welding, and relocate any objects that may be a fire hazard. When welding in a cab, make sure the interior surfaces are covered (e.g., welding blanket) and a fire extinguisher is at hand.
- Always use extreme caution when cutting and trimming during fitting.
- Always tighten all nuts and bolts securely per installation instructions.
- Always route electrical cables carefully. Avoid moving parts, components that become hot, and rough or sharp edges.
- Always insulate and protect all exposed wiring and electrical terminals.
- Perform regular inspections and maintenance on mounts and hardware.

TABLE OF CONTENTS

- 2 SAFETY / DISCLAIMER
- 3 TABLE OF CONTENTS
- 4 A MESSAGE FROM THE OWNER
- 5 GETTING STARTED
- 6 PROVIDED MATERIAL
- 7 DISASSEMBLY
- 9 INSTALLATION
- 12 CONTACT

A MESSAGE FROM THE OWNER



Fab Fours' was born out of a passion for customizing vehicles and a love of the outdoors. Our engineering team uses the latest 3D design software to turn new product ideas into reality. In our factory, designs come to life with the combination of cutting edge technology for metal cutting and forming and an American workforce that puts its' heart and pride into every product.

From design and manufacturing, to quality and delivery, Fab Fours' mission is to be the market leader for steel truck and jeep accessories. We make sure a quality product is delivered on time, more than expected, better than expected to our customers.

Enjoy your new Fab Fours product. Welcome to the family!

Greg Higgs

FOUNDER, FAB FOURS

GETTING STARTED

Before you begin the installation process of your new Fab Fours product, we suggest laying out all materials and parts on a pad or protective surface.

Failure to fully account for all components before beginning installation may leave vehicle immobile until part is acquired. Refer to the next pages as an inventory check.

PROVIDED MATERIALS

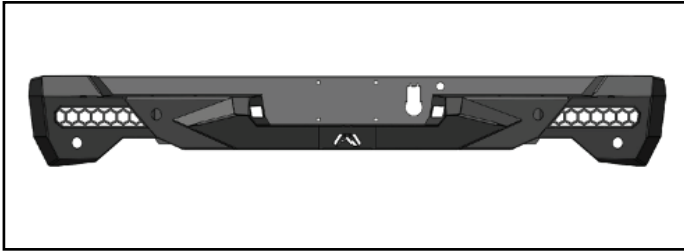

E455X-IM TXR Vengeance Rear

50169-HW

61632 2
EPOXY

61648 LIGHT
STRIP

HARDWARE KIT | 50169

FAB FOURS IDENTIFICATION	COMPONENT DESCRIPTION	QTY
50169-HW	7/16"-18 x 1 1/2", yellow zinc, hex cap screw, grade 8	4
50169-HW	7/16", yellow zinc, lock washer, grade 8	4
50169-HW	7/16", yellow zinc, flat washer, grade 8	8
50169-HW	7/16"-18, yellow zinc, hex nut, grade 8	4
50169-HW	Snap-in Round Plugs with Flexible Ridges, for 0.710"-0.820" ID	6
50169-HW	License plate nut insert, nylon	4

TOOLS REQUIRED

- 10mm Socket
- 12mm socket
- 13mm socket
- 15mm Socket
- 5/8 in Socket
- 11/16 in Socket
- T20 Star Head Socket
- Plastic Panel Pry Tool
- Pliers
- Flathead Screw Driver
- Zip ties

ASSISTANCE

We recommend two people perform the installation as items are heavy and may need to be held in place while installing.

ORGANIZATION

Disassemble the vehicle where you can catalog and store everything. We suggest labeling and bagging all the OEM bolts when removing from the vehicle. Failure to keep track of parts could lead to an inability to properly reinstall components.

ASSISTANCE

The 2019 Dodge Ram may have six (6), four (4), or no sensors in the rear bumper. This manual shows the six sensor configuration for illustration purposes but your specific installation may vary.

DISASSEMBLY

1. Using a body pry tool and a 15mm socket to remove the plastic cover and bolt located in the step. (Figure 1)



Figure 1

2. Disconnect the sensor and trailer plug harness by pulling back the red tab and separating the connectors. (Figure 2)



Figure 2

3. Using a 13mm socket wrench, remove the two bolts connecting the bumper to the frame on both the driver and passenger side. Remove the bumper from the truck (Figure 3)

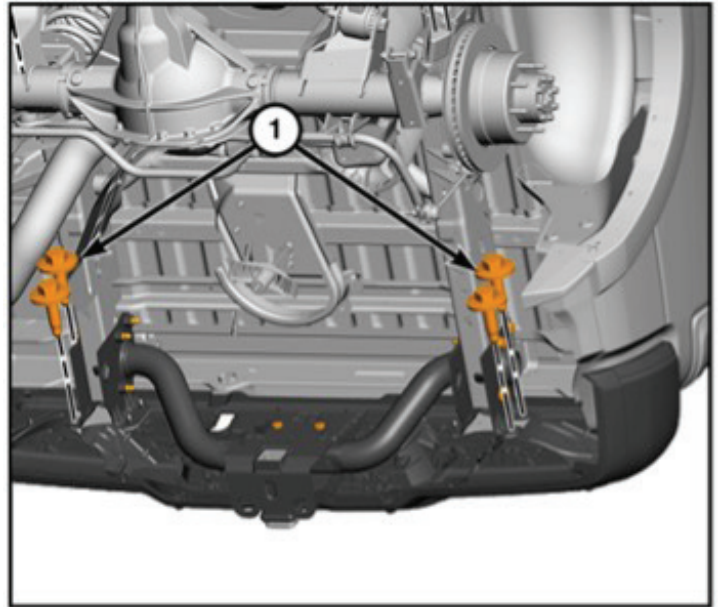

Figure 3

4. With the bumper off the truck, carefully unplug the wire harness from the trailer plug, license plate lights, keyless entry sensor and sensors. Using a plastic panel pry tool, remove the fasteners holding the harness to the OEM bumper. Remove the harness from the bumper and set aside for later use. (Figure 4-5)

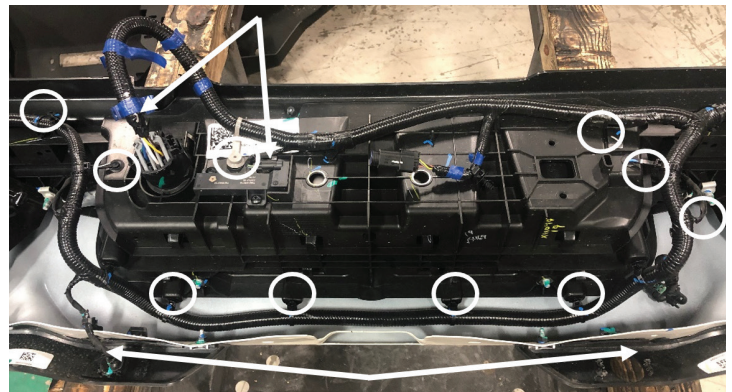

Figure 4



Figure 5

5. Carefully remove the four (4) sensors from the OEM bumper by separating the fastening clips (#1) and lifting the sensor (#2) out of its housing. (Figure 6)

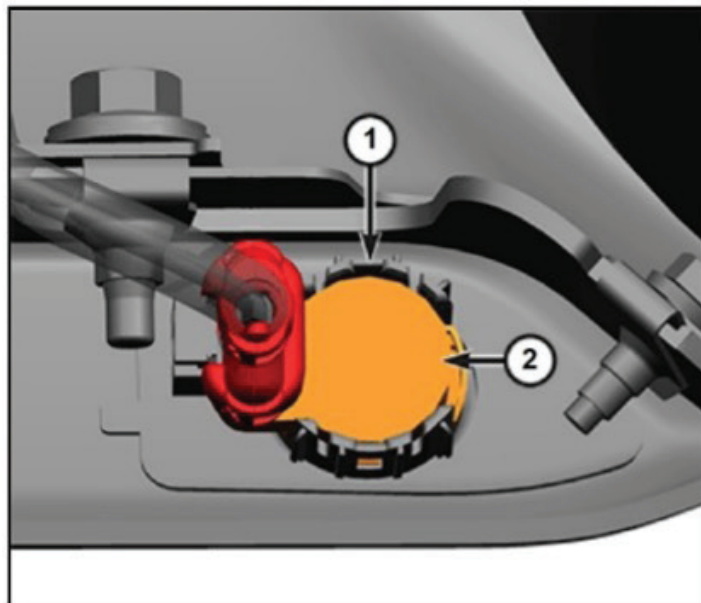

Figure 6

6. Using a body pry tool and a heat gun, remove all four sensor housings from the OEM bumper. Use the heat gun to carefully heat the adhesive around the sensor housing, then carefully pry the housings off the bumper. (Figure 7-8)

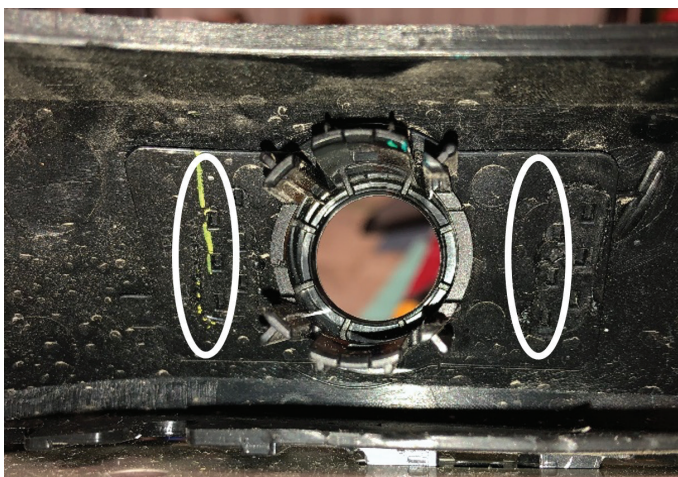

Figure 7



Figure 8

7. Using a 10 mm socket wrench, remove the bolt holding the license plate lights in place and remove the lights from the OEM bumper. (Figure 9)

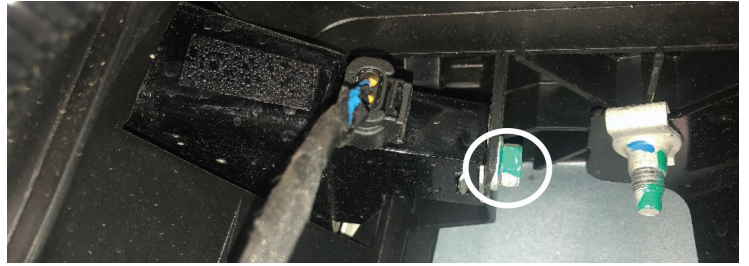

Figure 9

8. Using a T20 Star head socket wrench, remove the keyless entry sensor from the OEM bumper. (Figure 10)



Figure 10

9. Remove the trailer plug from the OEM bumper by depressing the two (2) metal clips on the sides and pushing the plug out of the bumper. (Figure 11)

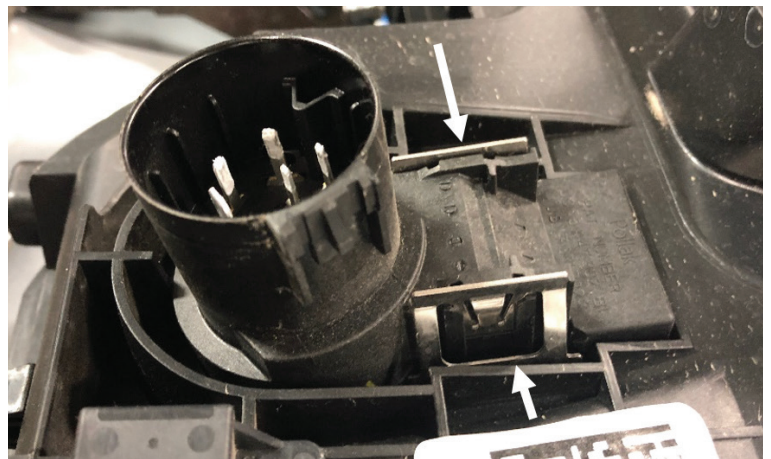

Figure 11

INSTALLATION

10. Figure 12 shows the components that will be used in your new Fab Fours bumper.



Figure 12

BUMPER INSTALL:

11. Using a 10mm socket wrench, install the license plate lights into the bumper. (Figure 14) NOTE: Do not over tighten the light bolt, the plastic housing is fragile and may break under too much pressure.

12. Use the provided epoxy (61632), install the four (4) sensor housings removed during step 7. Apply the epoxy to the outer edges of the housings and tape them in place until the epoxy has set. (Figure 13)



Figure 13

13. Using a flat head screw driver, install the trailer plug into the bumper by popping the locking clips into place. (Figure 14)

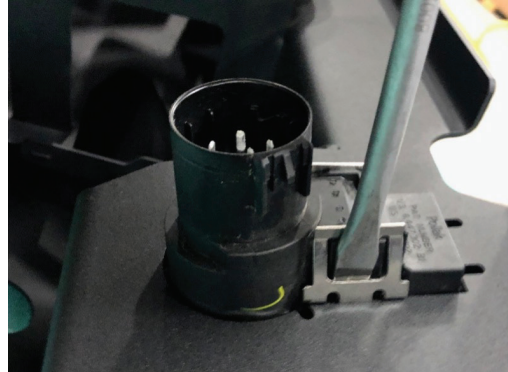

Figure 14

14. Using zip ties, install the keyless entry sensor to the OEM license plate bracket. (Figure 15)

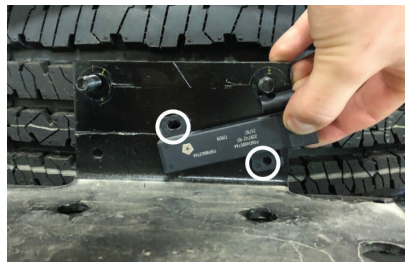

Figure 15

15. Install the provided light strip (61648) underneath the center step above the Fab Fours logo. Wire as desired depending on functionality. You can either wire to your brake lights, running lights or tag lights. (Figure 16)

Note: LED wiring color codes: RED = Hot. BLACK = Ground.



Figure 16

16. Use a 12mm socket wrench to remove the 5 bolts holding the bed step onto the frame. (Figure 17)



Figure 17

17. Pass the OEM wiring harness behind the brackets making sure to keep the plugs on the driver side of the truck. Reconnect the sensors, trailer plug and license plate lights. (Figure 18)

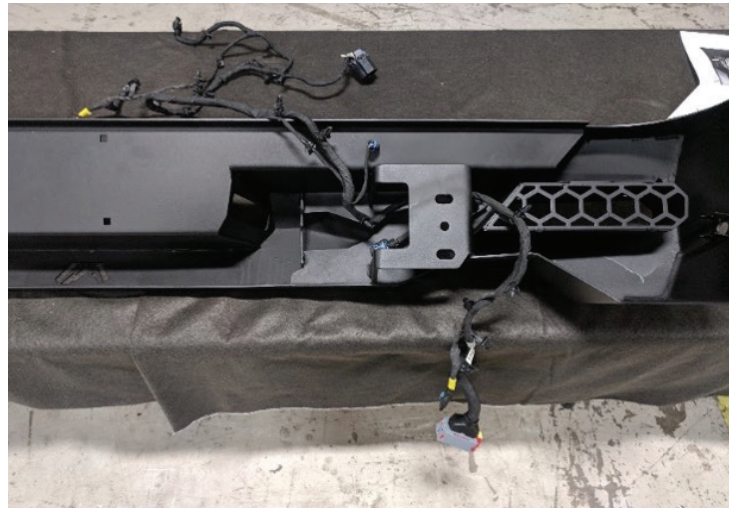

Figure 18

18. With assistance, hold the bumper to the truck and use the provided 7/16" yellow zinc bolts with flat/lock washers and nuts to attach it (502169-HW). (Figure 19)



Figure 19

19. Reconnect the keyless entry sensor to the wiring harness and plug the harness into the truck.

20. Insert the provided plastic license plate nuts into the bumper by pressing them into place (50169-HW). (Figure 20)

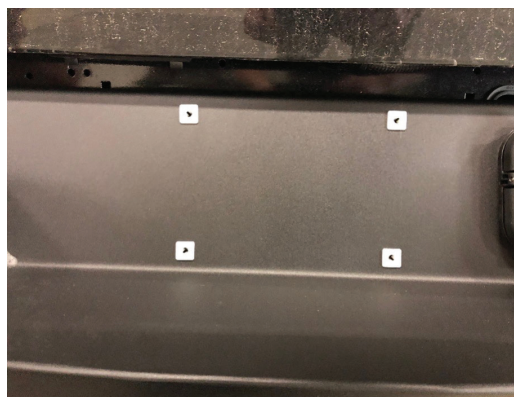

Figure 20

CONTACT INFORMATION

**FAB FOURS INC.
2213 INDUSTRIAL PARK ROAD
LANCASTER, SC 29720**

PHONE: (866) 385-1905

FAX: 970-385-1914

EMAIL: SUPPORT@FABFOURS.COM

FABFOURS.COM



**“IF YOU’RE LOOKING FOR MORE OF THE SAME,
THEN YOU’VE COME TO THE WRONG PLACE.”**

- GREG HIGGS

